



ALLIED MACHINE & ENGINEERING

Holemaking Solutions for Today's Manufacturing



Boring



Reaming



Burnishing



Threading



Specials



4TEX[®] Drill

► *DRILLING*

Indexable Carbide Insert Drilling System

SECTION

A55

4TEX® Drill

4TEX[®] Drill

Indexable Carbide Insert Drilling System

► **Diameter Range:** 0.472" - 1.850" (12.00 mm - 47.00 mm)



Don't Let Your Machine Slow You Down

The 4TEX indexable carbide drill provides increased penetration rates on light duty machines due to the single effective design. With twisted coolant outlets and increased core strength, the design provides improved hole size and finish.

The four sided 4TEX inserts are designed to use two sides in the center pocket and two sides in the periphery pocket for an improved cost per hole. With insert geometries available for all ISO material classes and a robust body design, the 4TEX is suited for your difficult applications.

Improved hole size and finish	Superior chip evacuation	Increased penetration rates
-------------------------------	--------------------------	-----------------------------

Applicable Industries



Aerospace



Agriculture



Automotive



Firearms



General
Machining



Oil & Gas



Renewable
Energy

Your safety and the safety of others is very important. This catalog contains important safety messages. Always read and follow all safety precautions.



This triangle is a safety hazard symbol. It alerts you to potential safety hazards that can cause tool failure and serious injury.

When you see this symbol in the catalog, look for a related safety message that may be near this triangle or referred to in the nearby text.

There are safety signal words also used in the catalog. Safety messages follow these words.

WARNING

WARNING (shown above) means that failure to follow the precautions in this message could result in tool failure and serious injury.

NOTICE means that failure to follow the precautions in this message could result in damage to the tool or machine but not result in personal injury.

NOTE and **IMPORTANT** are also used. These are important that you read and follow but are not safety-related.

Visit www.alliedmachine.com for the most up-to-date information and procedures.

Reference Icons

The following icons will appear throughout the catalog to help you navigate between products.



Setup / Assembly Information

Detailed instructions and information regarding the corresponding part(s)

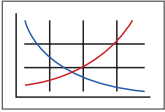

Recommended Cutting Data

Speed and feed recommendations for optimum and safe drilling

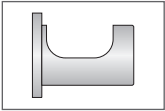

Eccentric Sleeves

Refers to the corresponding eccentric sleeve for the holder



Coolant-Through Option

Indicates that the product is coolant through

Series	Diameter Range	
	Imperial (inch)	Metric (mm)
03	0.472 - 0.531	12.00 - 13.49
04	0.532 - 0.610	13.50 - 15.49
05	0.611 - 0.728	15.50 - 18.49
06	0.728 - 0.866	18.50 - 21.99
07	0.867 - 1.043	22.00 - 26.49
09	1.044 - 1.259	26.50 - 31.99
11	1.260 - 1.535	32.00 - 38.99
14	1.536 - 1.850	39.00 - 47.00

Introduction Information

Safety Information 2

Case Study 3

Product Overview 4

Insert Information 5 - 6

Product Nomenclature 7

Drill Series

03 Series 8 - 9

04 Series 10 - 11

05 Series 12 - 13

06 Series 14 - 15

07 Series 16 - 17

09 Series 18 - 21

11 Series 22 - 25

14 Series 26 - 29

Eccentric Sleeves 30

Technical Information

Diameter Adjustment 31

Center Height Alignment 32 - 33

Recommended Cutting Data

Imperial (inch) 34

Metric (mm) 35

Insert Geometry Recommendations 36

Troubleshooting Guide 37

Safety Information



Mechanical / Physical Hazards

Operating cutting tools may present both mechanical and physical hazards. These hazards can result in serious injury to workers or those near machines and damage to machines and the cutting tools. Cutting tools and/or assemblies may break or come loose when in operation causing projectile metal fragments. Metal chips produced by cutting tools have sharp edges and may be very hot. To minimize the risk of mechanical or physical hazards:

- Always secure all components of the cutting tool assembly before operating.
- Wear cut-resistant gloves when handling cutting tool components and assemblies.
- Do not touch metal chips produced by the cutting tools with your hands.
- Always wear appropriate personal protective equipment including safety goggles or glasses with side shields.
- Immediately discontinue use of damaged cutting tools.
- To avoid machine tool damage, make sure the machine has adequate power and torque for the cutting tool when operating. See catalog for power and torque requirements.
- Operating long cutting tools at high spindle speeds can result in a high risk of tool failure and serious injury. Visit www.alliedmachine.com/DeepHoleGuidelines to read guidelines specific for deep hole drilling.

Dust and Fume Hazards

Grinding, welding, cutting or burning hard metals such as high-speed steel, cobalt or carbides produces hazardous dust and/or fumes. Continued long-term exposure to hazardous dust and fumes can cause serious health issues. To minimize the risk of dust and fume hazards:

- Do not regrind or sharpen cutting tools without using adequate ventilation.
- Use appropriate personal protective equipment such as approved respirator to avoid inhalation, swallowing, or skin contact with the hazardous dust and/or fumes.
- Do not eat, drink, or smoke in the machine operation area. Always wash skin prior to eating, drinking, or smoking to avoid hazardous ingestion.

Sensitizing Hazards

Components of an assembled cutting tool are made from a variety of metal elements that may cause allergic skin reactions with prolonged skin contact. To minimize the risk of allergic skin reactions:

- Avoid skin contact with cutting tools.
- Wear appropriate gloves and protective clothing.
- Wash skin and launder clothing after handling cutting tools to reduce the risk of skin allergies.

Preventive Safety Measure Applicable to all Hazards

- Prior to using cutting tools, always read Allied Machine's Safety Data Sheets, product catalog, and product labels for additional warnings for the Allied Machine product being used.
- For machining safety, only operate equipment when all necessary guards, interlocks and other safety devices are in place and functional. Use all appropriate safety guards or machine encapsulations to securely collect particles such as chips or cutting elements that may become projectiles.

Through Hole

- With through holes, a **sharp-edged disk** is created as tool breakout occurs.
 - ⚠ Proper personal protective equipment must be used to prevent injury (e.g. wear cut-resistant gloves).



Case Study

Do you need performance in extreme machining conditions?

Tooling is only a sliver of the pie when it comes to productivity. It doesn't matter what your tooling is capable of if your machine conditions restrict those capabilities. Our customer, who drills holes for machine gun bolt switches, utilizes a machine with oil coolant that creates more extreme drilling conditions than water-based coolant.



Because oil coolant doesn't dissipate heat fast enough, the customer's tooling only lasted for 160 holes per insert, and the tool experienced sporadic failure. They also needed to run a peck cycle for chip control.

The customer decided to test the **4TEX indexable carbide drill** using the "P" geometry with AM480 coating designed specifically for wear-resistance in steel material applications. The 4TEX "P" geometry allowed for the speed and feed to be altered and accommodated the machine's oil coolant. The 4TEX penetration rate was able to decrease cycle time and also double the tool life to 320 holes per insert. The 4TEX geometry also improved chip formation and eliminated the peck cycle.

The 4TEX provided the stable and repeatable process the customer was looking for while increasing tool life by 100%. With all their objectives met, the customer was thrilled with the solution that optimized their machine's limitations. **Are you using the solution that best optimizes your machine's limitations?**

Product:	4TEX® Drill	Measure	Competitor IC Drill	4TEX® Drill
Objectives:	(1) Exceed 160 holes per insert (2) Eliminate peck cycle (3) Provide stable/repeatable process	RPM	2075	1223
		Speed Rate	509 SFM (155.1432 M/min)	300 SFM (91.44 M/min)
		Feed Rate	0.0015 IPR (0.0381 mm/rev)	0.003 IPR (0.0762 mm/rev)
Industry:	Firearms	Penetration Rate	3.11 IPM (78.994 mm/min)	3.67 IPM (93.219 mm/min)
Part:	Machine gun bolt switch hole	Peck Cycle	Yes	No
Material:	4340 steel	Cycle Time	16 sec	9 sec
Hole Ø:	0.937" (23.7998 mm)	Tool Life	160 holes per insert	320 holes per insert
Hole Depth:	0.590" (14.986 mm)			

- ▶ 4TEX Drill holder
2xD length
Item No. D2070937I-100F

- ▶ 4TEX Drill inserts
P geometry (steel)
Item No. 4T-070305-P

*100%
tool life increase*

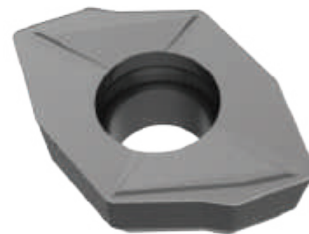

The 4-sided indexable inserts with wear-resistant coating provided:

- ✓ Increased tool life
- ✓ Decreased cycle time
- ✓ Worry-free machining

Product Overview

4TEX Drill *Advantages*

- ✓ **Superior chip evacuation**
provided by the two twisted coolant holes
- ✓ **Improved hole size**
from the increased holder rigidity
- ✓ **Longer tool life**
provided by the four-sided insert design
- ✓ **Optimal chip formation**
with ISO-specific insert geometry/coating combinations
- ✓ **Competitive cycle times**
due to single effective cutting when using light duty machines

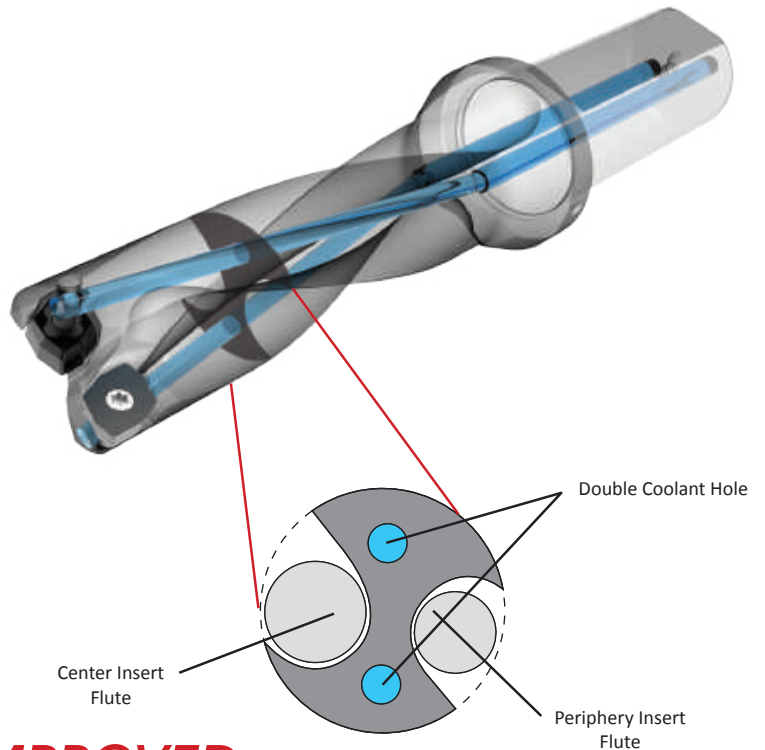

DESIGNED TO GIVE YOU *IMPROVED* HOLE SIZE AND STRAIGHTNESS

- The two twisted coolant holes allow the core to remain intact, making the core thicker and stronger for improved hole straightness even in uneven surfaces.
- The enlarged dual coolant outlets increase the coolant volume, which improved the chip evacuation resulting in improved hole size.
- The flute space of the internal cutting edge side (where chips get stuck most often) is 1.6x larger than typical IC drills, helping to mitigate catastrophic failures and improve hole size.

LONGER TOOL LIFE

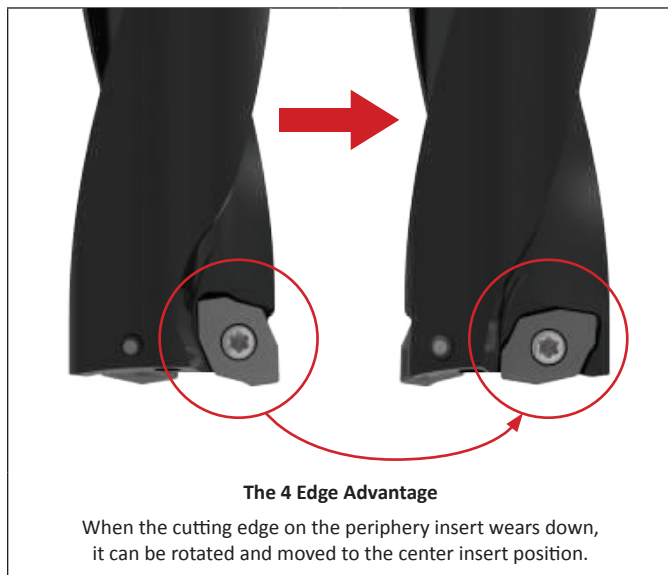

AVAILABLE *LENGTHS*

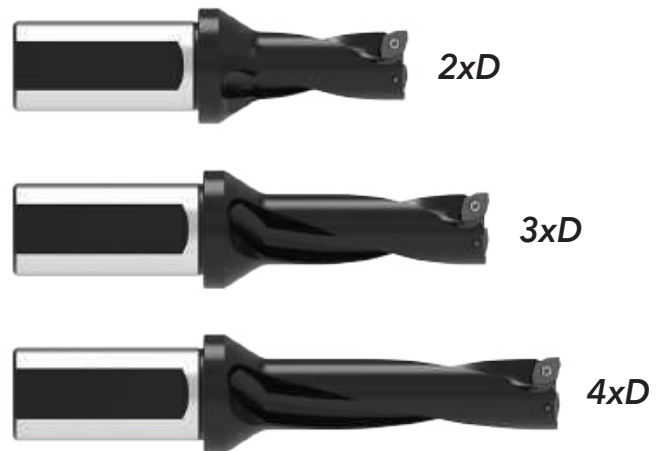

A DRILLING
B BORING
C REAMING
D BURNISHING
E THREADING
X SPECIALS



Insert Information

4 CUTTING EDGES

- Each insert has two inner cutting edges and two outer cutting edges
- Economical solution that increases tool life because of the rotation ability of the inserts
- Available in ISO material-specific geometry/coating combinations

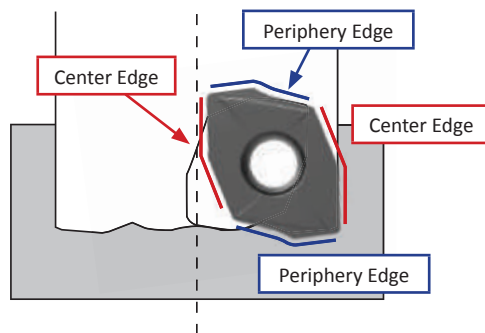

Periphery Insert



Periphery edge chip formation:



Center Insert





Center edge chip formation:



ISO Material	Geometry	Coating	Description
P	General Rake	AM480	A general purpose geometry that provides excellent chip formation in most steels including free-machining, medium- and high-carbon steels. A P30 carbide substrate for improved toughness and AM480 coating, a proprietary wear resistant multilayer PVD coating to improve tool life.
S M	High Rake	AM485	A higher rake geometry that provides excellent chip formation in both stainless steels and high-temperature alloys. A tough M25 carbide substrate coated with AM485, a high heat resistance proprietary multilayer PVD coating.
H	Low Rake	AM480	A lower rake geometry to improve edge strength in both hardened tool steels and high-strength alloys. With a P30 carbide substrate for improved toughness and coated with AM480, a proprietary multilayer PVD coating to improve resistance against tool wear.
K	General Rake	AM480	With a general purpose geometry, the K inserts can be used in grey cast irons as well as ductile irons. A high wear-resistant K10 carbide substrate to improve tool life and coated with AM480, a proprietary multilayer PVD coating to improve resistance against tool wear.
N	High Rake	TiCN	A higher rake cutting geometry provides excellent chip formation in nonferrous materials. An M15/K15 carbide substrate paired with TiCN coating for improved lubricity to resist built-up material, increasing tool life and maintaining chip formation.

Insert Information

Series	Insert Prefix	Dimension (mm)					Angle		Shape
		L_1	L_2	T	D_1	R	A_1	A_2	
03	4T-030203C-x	5.60	4.80	2.30	2.40	0.30	7°	10°	 Style 1
	4T-030203P-x	6.38	4.77	2.30	2.40	0.30	7°	10°	 Style 2
04	4T-040203-x	6.21	5.06	2.60	2.45	0.30	13°	10°	 Style 3
05	4T-05T203-x	7.26	5.48	2.76	2.55	0.30	13°	7°	
06	4T-06T204-x	8.59	6.44	2.89	2.79	0.40	13°	7°	
07	4T-070305-x	10.21	8.02	3.24	3.00	0.50	13°	7°	
09	4T-09T306-x	12.18	9.55	4.03	3.64	0.60	13°	7°	
11	4T-11T306-x	14.50	11.61	4.06	4.62	0.60	13°	7°	
14	4T-140408-x	17.99	14.40	4.88	5.76	0.80	13°	7°	

Style 1

Style 2

Style 3

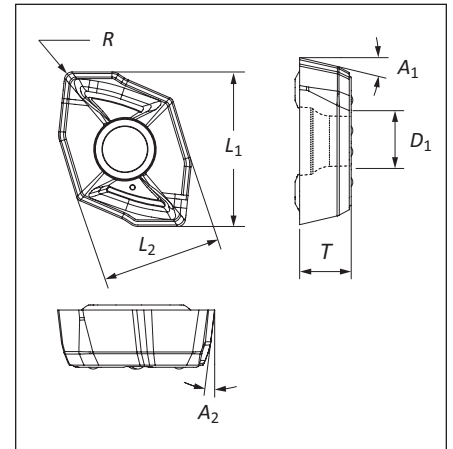
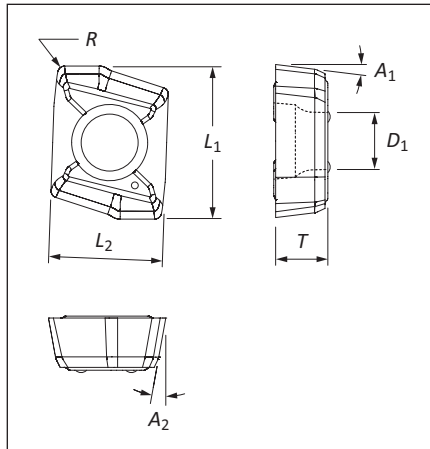
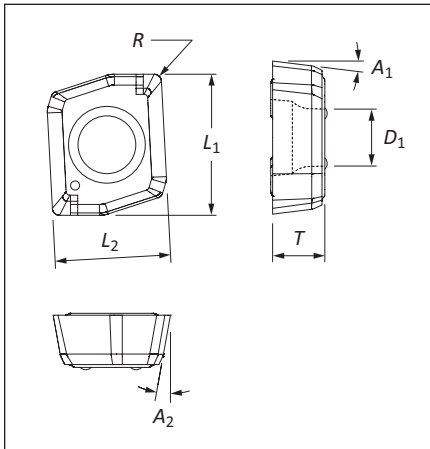

A DRILLING
B BORING
C REAMING
D BURNISHING
E THREADING
X SPECIALS

Product Nomenclature

4TEX Drill Holders

D4	03	1200	M	-	075	F
1	2	3*	4		5	6

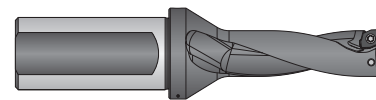

1. Length-to-Diameter-Ratio
D2 = 2xD
D3 = 3xD
D4 = 4xD

2. Series	
03 = 03 series	07 = 07 series
04 = 04 series	09 = 09 series
05 = 05 series	11 = 11 series
06 = 06 series	14 = 14 series

3. Diameter*
0750 = .075"
1200 = 12mm

4. Diameter Style
I = Imperial
M = Metric

5. Shank Diameter	
Imperial	Metric
075 = 0.75"	20 = 20 mm
100 = 1.000"	25 = 25 mm
125 = 1.250"	32 = 32 mm
150 = 1.500"	40 = 40 mm

6. Shank Style
F = Imperial flanged shank
FM = Metric flanged shank

***Ordering Nonstocked Diameters:**

Non-stocked diameters are available upon request. Please refer to price list for applicable process fees.

Ordering example:

Inch: 03 Series (∅ .480") = D2030480I-075F

Metric: 03 Series (12.65 mm) = D2031265M-20FM

Reference Key

Symbol	Attribute
D₁	Drill diameter
D₂	Shank diameter
D₃	Flange diameter
L₁	Assembled overall length
L₂	Drill depth
L₃	Reference length

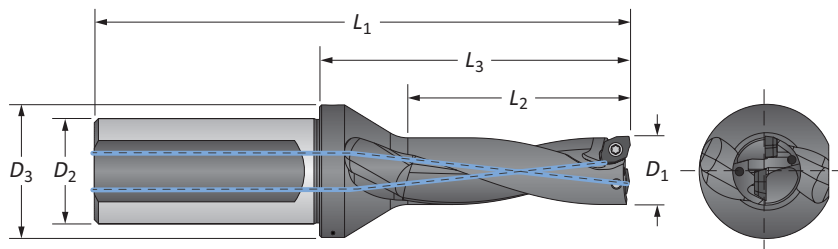

A

DRILLING

B

BORING

C

REAMING

D

BURNISHING

E

THREADING

X

SPECIALS

4TEX Drill Holders | Imperial Shank

03 Series | Diameter Range: 0.472" - 0.531" (12.00 mm - 13.49 mm)

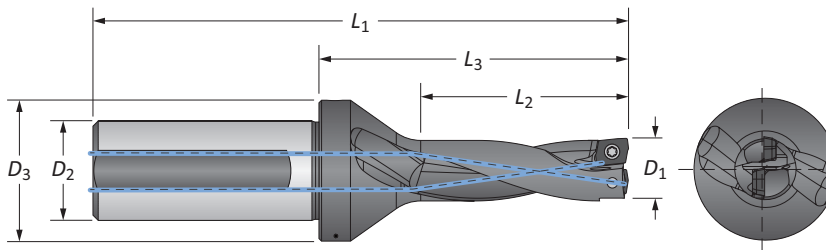

Imperial Shank

Length	D ₁		Body			Shank		Max Offset	Part No.
	in	mm	L ₂	L ₃	L ₁	D ₂	D ₃		
2xD	0.472	12.00	0.945	1.787	3.480	0.750	1.063	0.020	D2031200M-075F
	0.492	12.50	0.984	1.827	3.520	0.750	1.063	0.016	D2031250M-075F
	0.500	12.70	1.000	1.827	3.520	0.750	1.063	0.014	D2030500I-075F
	0.512	13.00	1.024	1.866	3.559	0.750	1.063	0.012	D2031300M-075F
3xD	0.472	12.00	1.417	2.260	3.953	0.750	1.063	0.020	D3031200M-075F
	0.492	12.50	1.476	2.319	4.012	0.750	1.063	0.016	D3031250M-075F
	0.500	12.70	1.500	2.319	4.012	0.750	1.063	0.014	D3030500I-075F
	0.512	13.00	1.535	2.378	4.071	0.750	1.063	0.012	D3031300M-075F
4xD	0.472	12.00	1.890	2.732	4.425	0.750	1.063	0.020	D4031200M-075F
	0.492	12.50	1.969	2.811	4.504	0.750	1.063	0.016	D4031250M-075F
	0.500	12.70	2.000	2.811	4.504	0.750	1.063	0.014	D4030500I-075F
	0.512	13.00	2.047	2.890	4.583	0.750	1.063	0.012	D4031300M-075F

IC Inserts

ISO Material	Style	Part No.	Insert Screw	Torx® Driver	Admissible Tightening Torque
P	Center	4T-030203C-P	7241-T6-1	8T-6	4.4 in-lbs (0.5 N-m)
	Periphery	4T-030203P-P			
S M	Center	4T-030203C-M			
	Periphery	4T-030203P-M			
H	Center	4T-030203C-H			
	Periphery	4T-030203P-H			
K	Center	4T-030203C-K			
	Periphery	4T-030203P-K			
N	Center	4T-030203C-N			
	Periphery	4T-030203P-N			

Expected Hole Tolerances

Length	in	mm
2xD	-.004 / +.008	-.10 / +.20
3xD	-.004 / +.008	-.10 / +.20
4xD	-.004 / +.010	-.10 / +.25

A55: 34 - 35

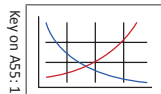

A55: 31 - 33



A55: 30

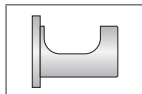

Key on A55: 1

i = Imperial (in)
m = Metric (mm)

IC inserts sold in quantities of 10
Insert screws sold in quantities of 10

4TEX Drill Holders | Metric Shank

03 Series | Diameter Range: 0.472" - 0.531" (12.00 mm - 13.49 mm)

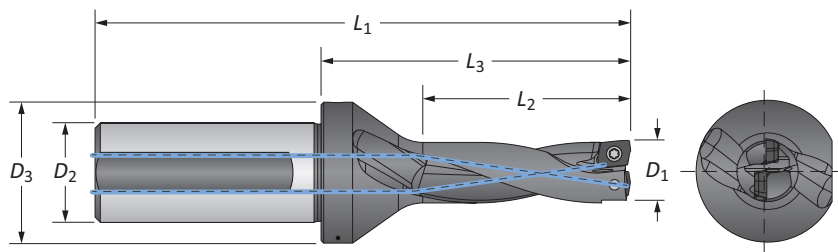

Metric Shank

Length	D ₁		Body			Shank		Max Offset	Part No.
	in	mm	L ₂	L ₃	L ₁	D ₂	D ₃		
2xD	0.472	12.00	24.00	45.40	88.40	20.00	27.00	0.50	D2031200M-20FM
	0.492	12.50	25.00	46.40	89.40	20.00	27.00	0.40	D2031250M-20FM
	0.500	12.70	25.40	46.40	89.40	20.00	27.00	0.35	D2030500I-20FM
	0.512	13.00	26.00	47.40	90.40	20.00	27.00	0.30	D2031300M-20FM
3xD	0.472	12.00	36.00	57.40	100.40	20.00	27.00	0.50	D3031200M-20FM
	0.492	12.50	37.50	58.90	101.90	20.00	27.00	0.40	D3031250M-20FM
	0.500	12.70	38.10	58.90	101.90	20.00	27.00	0.35	D3030500I-20FM
	0.512	13.00	39.00	60.40	103.40	20.00	27.00	0.30	D3031300M-20FM
4xD	0.472	12.00	48.00	69.40	112.40	20.00	27.00	0.50	D4031200M-20FM
	0.492	12.50	50.00	71.40	114.40	20.00	27.00	0.40	D4031250M-20FM
	0.500	12.70	50.80	71.40	114.40	20.00	27.00	0.35	D4030500I-20FM
	0.512	13.00	52.00	73.40	116.40	20.00	27.00	0.30	D4031300M-20FM

IC Inserts

ISO Material	Style	Part No.	Insert Screw	Torx® Driver	Admissible Tightening Torque
P	Center	4T-030203C-P	7241-T6-1	8T-6	4.4 in-lbs (0.5 N-m)
	Periphery	4T-030203P-P			
S M	Center	4T-030203C-M			
	Periphery	4T-030203P-M			
H	Center	4T-030203C-H			
	Periphery	4T-030203P-H			
K	Center	4T-030203C-K			
	Periphery	4T-030203P-K			
N	Center	4T-030203C-N			
	Periphery	4T-030203P-N			

Expected Hole Tolerances

Length	in	mm
2xD	-.004 / +.008	-.10 / +.20
3xD	-.004 / +.008	-.10 / +.20
4xD	-.004 / +.010	-.10 / +.25

A55: 34 - 35

A55: 31 - 33

A55: 30

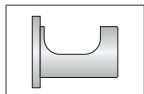
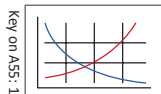

Key on A55: 1

ⓘ = Imperial (in)
Ⓜ = Metric (mm)

IC inserts sold in quantities of 10
Insert screws sold in quantities of 10

4TEX Drill Holders | Imperial Shank

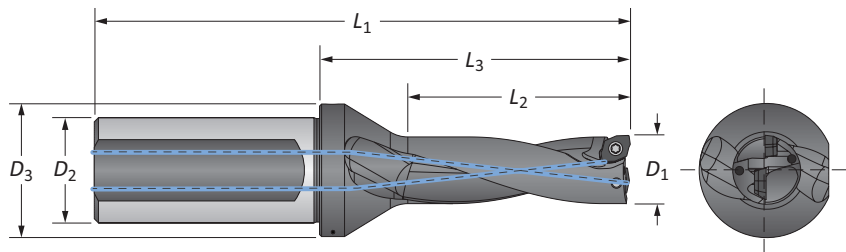

04 Series | Diameter Range: 0.532" - 0.610" (13.50 mm - 15.49 mm)



Imperial Shank

Length	D ₁		Body			Shank		Max Offset	Part No.
	in	mm	L ₂	L ₃	L ₁	D ₂	D ₃		
2xD	0.531	13.50	1.063	1.906	3.598	0.750	1.063	0.020	D2041350M-075F
	0.551	14.00	1.102	1.945	3.638	0.750	1.063	0.016	D2041400M-075F
	0.563	14.29	1.124	1.945	3.638	0.750	1.063	0.013	D2040562I-075F
	0.571	14.50	1.142	1.984	3.677	0.750	1.063	0.012	D2041450M-075F
	0.591	15.00	1.181	2.024	3.717	0.750	1.063	0.008	D2041500M-075F
3xD	0.531	13.50	1.594	2.437	4.130	0.750	1.063	0.020	D3041350M-075F
	0.551	14.00	1.654	2.496	4.189	0.750	1.063	0.016	D3041400M-075F
	0.563	14.29	1.686	2.496	4.189	0.750	1.063	0.013	D3040562I-075F
	0.571	14.50	1.713	2.555	4.248	0.750	1.063	0.012	D3041450M-075F
	0.591	15.00	1.772	2.614	4.307	0.750	1.063	0.008	D3041500M-075F
4xD	0.531	13.50	2.126	2.969	4.661	0.750	1.063	0.020	D4041350M-075F
	0.551	14.00	2.205	3.047	4.740	0.750	1.063	0.016	D4041400M-075F
	0.563	14.29	2.248	3.047	4.740	0.750	1.063	0.013	D4040562I-075F
	0.571	14.50	2.283	3.126	4.819	0.750	1.063	0.012	D4041450M-075F
	0.591	15.00	2.362	3.205	4.898	0.750	1.063	0.008	D4041500M-075F

IC Inserts

ISO Material	Part No.	Insert Screw	Torx® Driver	Admissible Tightening Torque
P	4T-040203-P	 7241-T6-1	 8T-6	4.4 in-lbs (0.5 N-m)
S	4T-040203-M			
H	4T-040203-H			
K	4T-040203-K			
N	4T-040203-N			

Expected Hole Tolerances

Length	in	mm
2xD	-0.004 / +.008	-.10 / +.20
3xD	-0.004 / +.008	-.10 / +.20
4xD	-0.004 / +.010	-.10 / +.25

A55: 34 - 35

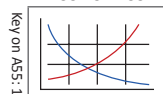

A55: 31 - 33



A55: 30

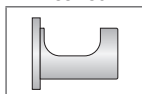

4TEX Drill Holders | Metric Shank

04 Series | Diameter Range: 0.532" - 0.610" (13.50 mm - 15.49 mm)

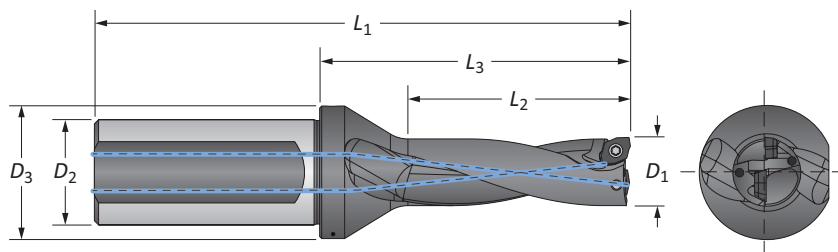

Metric Shank

Length	D ₁		Body			Shank		Max Offset	Part No.
	in	mm	L ₂	L ₃	L ₁	D ₂	D ₃		
2xD	0.531	13.50	27.00	48.40	91.40	20.00	27.00	0.50	D2041350M-20FM
	0.551	14.00	28.00	49.40	92.40	20.00	27.00	0.40	D2041400M-20FM
	0.563	14.29	28.55	49.40	92.40	20.00	27.00	0.30	D2040562I-20FM
	0.571	14.50	29.00	50.40	93.40	20.00	27.00	0.30	D2041450M-20FM
	0.591	15.00	30.00	51.40	94.40	20.00	27.00	0.20	D2041500M-20FM
3xD	0.531	13.50	40.50	61.90	104.90	20.00	27.00	0.50	D3041350M-20FM
	0.551	14.00	42.00	63.40	106.40	20.00	27.00	0.40	D3041400M-20FM
	0.563	14.29	42.82	63.40	106.40	20.00	27.00	0.30	D3040562I-20FM
	0.571	14.50	43.50	64.90	107.90	20.00	27.00	0.30	D3041450M-20FM
	0.591	15.00	45.00	66.40	109.40	20.00	27.00	0.20	D3041500M-20FM
4xD	0.531	13.50	54.00	75.40	118.40	20.00	27.00	0.50	D4041350M-20FM
	0.551	14.00	56.00	77.40	120.40	20.00	27.00	0.40	D4041400M-20FM
	0.563	14.29	57.10	77.40	120.40	20.00	27.00	0.30	D4040562I-20FM
	0.571	14.50	58.00	79.40	122.40	20.00	27.00	0.30	D4041450M-20FM
	0.591	15.00	60.00	81.40	124.40	20.00	27.00	0.20	D4041500M-20FM

IC Inserts

ISO Material	Part No.	Insert Screw	Torx® Driver	Admissible Tightening Torque
P	4T-040203-P	7241-T6-1	8T-6	4.4 in-lbs (0.5 N-m)
S	4T-040203-M			
H	4T-040203-H			
K	4T-040203-K			
N	4T-040203-N			

Expected Hole Tolerances

Length	in	mm
2xD	-.004 / +.008	-.10 / +.20
3xD	-.004 / +.008	-.10 / +.20
4xD	-.004 / +.010	-.10 / +.25

Key on ASS: 1

A55: 34 - 35

A55: 31 - 33

A55: 30

ⓘ = Imperial (in)
 ⓘ = Metric (mm)

IC inserts sold in quantities of 10
 Insert screws sold in quantities of 10

4TEX Drill Holders | Imperial Shank

05 Series | Diameter Range: 0.611" - 0.728" (15.50 mm - 18.49 mm)

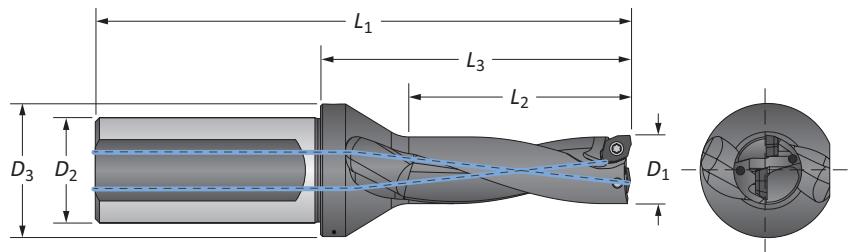

Imperial Shank

Length	D ₁		Body			Shank		Max Offset	Part No.
	in	mm	L ₂	L ₃	L ₁	D ₂	D ₃		
2xD	0.610	15.50	1.220	2.146	4.272	1.000	1.260	0.031	D2051550M-100F
	0.625	15.88	1.250	2.146	4.272	1.000	1.260	0.029	D2050625I-100F
	0.630	16.00	1.260	2.185	4.311	1.000	1.260	0.028	D2051600M-100F
	0.650	16.50	1.299	2.224	4.350	1.000	1.260	0.020	D2051650M-100F
	0.656	16.66	1.312	2.224	4.350	1.000	1.260	0.016	D2050656I-100F
	0.669	17.00	1.339	2.264	4.390	1.000	1.260	0.016	D2051700M-100F
	0.687	17.46	1.374	2.264	4.390	1.000	1.260	0.012	D2050687I-100F
	0.689	17.50	1.378	2.303	4.429	1.000	1.260	0.012	D2051750M-100F
	0.709	18.00	1.417	2.343	4.469	1.000	1.260	0.008	D2051800M-100F
0.718	18.24	1.436	2.343	4.469	1.000	1.260	0.006	D2050718I-100F	
3xD	0.610	15.50	1.831	2.756	4.882	1.000	1.260	0.031	D3051550M-100F
	0.625	15.88	1.875	2.756	4.882	1.000	1.260	0.029	D3050625I-100F
	0.630	16.00	1.890	2.815	4.941	1.000	1.260	0.028	D3051600M-100F
	0.650	16.50	1.949	2.874	5.000	1.000	1.260	0.020	D3051650M-100F
	0.656	16.66	1.968	2.784	5.000	1.000	1.260	0.016	D3050656I-100F
	0.669	17.00	2.008	2.933	5.059	1.000	1.260	0.016	D3051700M-100F
	0.687	17.46	2.061	2.933	5.059	1.000	1.260	0.012	D3050687I-100F
	0.689	17.50	2.067	2.992	5.118	1.000	1.260	0.012	D3051750M-100F
	0.709	18.00	2.126	3.051	5.177	1.000	1.260	0.008	D3051800M-100F
0.718	18.24	2.154	3.051	5.177	1.000	1.260	0.006	D3050718I-100F	
4xD	0.610	15.50	2.441	3.366	5.492	1.000	1.260	0.031	D4051550M-100F
	0.625	15.88	2.500	3.366	5.492	1.000	1.260	0.029	D4050625I-100F
	0.630	16.00	2.520	3.445	5.571	1.000	1.260	0.028	D4051600M-100F
	0.650	16.50	2.598	3.524	5.650	1.000	1.260	0.020	D4051650M-100F
	0.656	16.66	2.624	3.524	5.650	1.000	1.260	0.016	D4050656I-100F
	0.669	17.00	2.677	3.602	5.728	1.000	1.260	0.016	D4051700M-100F
	0.687	17.46	2.748	3.602	5.728	1.000	1.260	0.012	D4050687I-100F
	0.689	17.50	2.756	3.681	5.807	1.000	1.260	0.012	D4051750M-100F
	0.709	18.00	2.835	3.760	5.886	1.000	1.260	0.008	D4051800M-100F
0.718	18.24	2.872	3.760	5.886	1.000	1.260	0.006	D4050718I-100F	

IC Inserts

ISO Material	Part No.	Insert Screw	Torx® Driver	Admissible Tightening Torque
P	4T-05T203-P	7243-T6-1	8T-6	4.4 in-lbs (0.5 N-m)
S	4T-05T203-M			
M	4T-05T203-M			
H	4T-05T203-H			
K	4T-05T203-K			
N	4T-05T203-N			

Expected Hole Tolerances

Length	in	mm
2xD	-0.004 / +0.008	-0.10 / +0.20
3xD	-0.004 / +0.008	-0.10 / +0.20
4xD	-0.004 / +0.010	-0.10 / +0.25

A55: 34 - 35

A55: 31 - 33

A55: 30

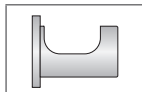
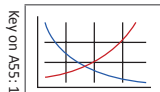

ⓘ = Imperial (in)
 ⓘ = Metric (mm)

IC inserts sold in quantities of 10
 Insert screws sold in quantities of 10

4TEX Drill Holders | Metric Shank

05 Series | Diameter Range: 0.611" - 0.728" (15.50 mm - 18.49 mm)

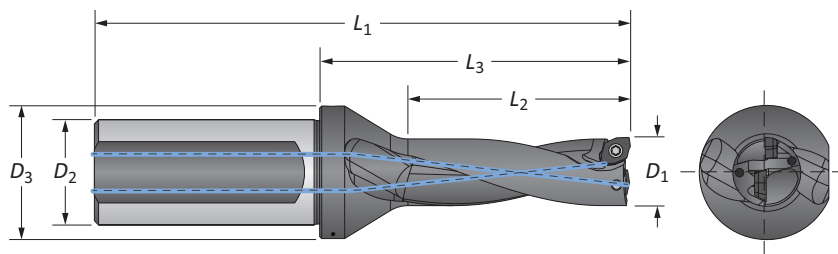

Metric Shank

Length	D ₁		Body			Shank		Max Offset	Part No.
	in	mm	L ₂	L ₃	L ₁	D ₂	D ₃		
2xD	0.610	15.50	31.00	54.50	108.50	25.00	32.00	0.80	D2051550M-25FM
	0.625	15.88	31.75	54.50	108.50	25.00	32.00	0.70	D2050625I-25FM
	0.630	16.00	32.00	55.50	109.50	25.00	32.00	0.70	D2051600M-25FM
	0.650	16.50	33.00	56.50	110.50	25.00	32.00	0.50	D2051650M-25FM
	0.656	16.66	33.32	56.49	110.50	25.00	32.00	0.40	D2050656I-25FM
	0.669	17.00	34.00	57.50	111.50	25.00	32.00	0.40	D2051700M-25FM
	0.687	17.46	34.90	57.50	111.50	25.00	32.00	0.30	D2050687I-25FM
	0.689	17.50	35.00	58.50	112.50	25.00	32.00	0.30	D2051750M-25FM
	0.709	18.00	36.00	59.50	113.50	25.00	32.00	0.20	D2051800M-25FM
0.718	18.24	36.47	59.51	113.51	25.00	32.00	0.15	D2050718I-25FM	
3xD	0.610	15.50	46.50	70.00	124.00	25.00	32.00	0.80	D3051550M-25FM
	0.625	15.88	47.63	70.00	124.00	25.00	32.00	0.70	D3050625I-25FM
	0.630	16.00	48.00	71.50	125.50	25.00	32.00	0.70	D3051600M-25FM
	0.650	16.50	49.50	73.00	127.00	25.00	32.00	0.50	D3051650M-25FM
	0.656	16.66	49.98	73.00	127.00	25.00	32.00	0.40	D3050656I-25FM
	0.669	17.00	51.00	74.50	128.50	25.00	32.00	0.40	D3051700M-25FM
	0.687	17.46	52.35	74.50	128.50	25.00	32.00	0.30	D3050687I-25FM
	0.689	17.50	52.50	76.00	130.00	25.00	32.00	0.30	D3051750M-25FM
	0.709	18.00	54.00	77.50	131.50	25.00	32.00	0.20	D3051800M-25FM
0.718	18.24	54.71	77.50	131.50	58.00	32.00	0.15	D3050718I-25FM	
4xD	0.610	15.50	62.00	85.50	139.50	25.00	32.00	0.80	D4051550M-25FM
	0.625	15.88	63.50	85.50	139.50	25.00	32.00	0.70	D4050625I-25FM
	0.630	16.00	64.00	87.50	141.50	25.00	32.00	0.70	D4051600M-25FM
	0.650	16.50	66.00	89.50	143.50	25.00	32.00	0.50	D4051650M-25FM
	0.656	16.66	66.64	89.51	143.51	25.00	32.00	0.40	D4050656I-25FM
	0.669	17.00	68.00	91.50	145.50	25.00	32.00	0.40	D4051700M-25FM
	0.687	17.46	69.80	91.50	145.50	25.00	32.00	0.30	D4050687I-25FM
	0.689	17.50	70.00	93.50	147.50	25.00	32.00	0.30	D4051750M-25FM
	0.709	18.00	72.00	95.50	149.50	25.00	32.00	0.20	D4051800M-25FM
0.718	18.24	72.95	95.50	149.50	25.00	32.00	0.15	D4050718I-25FM	

IC Inserts

ISO Material	Part No.	Insert Screw	Torx® Driver	Admissible Tightening Torque
P	4T-05T203-P	7243-T6-1	8T-6	4.4 in-lbs (0.5 N-m)
S M	4T-05T203-M			
H	4T-05T203-H			
K	4T-05T203-K			
N	4T-05T203-N			

Expected Hole Tolerances

Length	in	mm
2xD	-.004 / +.008	-.10 / +.20
3xD	-.004 / +.008	-.10 / +.20
4xD	-.004 / +.010	-.10 / +.25

Key on ASS: 1

A55: 34 - 35

A55: 31 - 33

A55: 30

ⓘ = Imperial (in)
 ⓘ = Metric (mm)

IC inserts sold in quantities of 10
 Insert screws sold in quantities of 10

4TEX Drill Holders | Imperial Shank

06 Series | Diameter Range: 0.728" - 0.866" (18.50 mm - 21.99 mm)

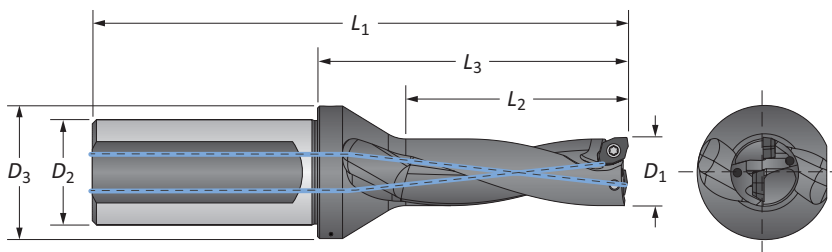

Imperial Shank

Length	D ₁		Body			Shank		Max Offset	Part No.
	in	mm	L ₂	L ₃	L ₁	D ₂	D ₃		
2xD	0.728	18.50	1.457	2.299	4.425	1.000	1.260	0.035	D2061850M-100F
	0.748	19.00	1.496	2.339	4.465	1.000	1.260	0.031	D2061900M-100F
	0.750	19.05	1.500	2.339	4.465	1.000	1.260	0.031	D2060750I-100F
	0.765	19.43	1.530	2.339	4.465	1.000	1.260	0.028	D2060765I-100F
	0.768	19.50	1.535	2.378	4.504	1.000	1.260	0.028	D2061950M-100F
	0.787	20.00	1.575	2.417	4.543	1.000	1.260	0.020	D2062000M-100F
	0.807	20.50	1.614	2.457	4.583	1.000	1.260	0.016	D2062050M-100F
	0.813	20.64	1.624	2.457	4.583	1.000	1.260	0.015	D2060812I-100F
	0.827	21.00	1.654	2.496	4.622	1.000	1.260	0.012	D2062100M-100F
3xD	0.846	21.50	1.693	2.535	4.661	1.000	1.260	0.008	D2062150M-100F
	0.728	18.50	2.165	3.028	5.154	1.000	1.260	0.035	D3061850M-100F
	0.748	19.00	2.244	3.087	5.213	1.000	1.260	0.031	D3061900M-100F
	0.750	19.05	2.250	3.087	5.213	1.000	1.260	0.031	D3060750I-100F
	0.765	19.43	2.295	3.087	5.213	1.000	1.260	0.028	D3060765I-100F
	0.768	19.50	2.303	3.146	5.272	1.000	1.260	0.028	D3061950M-100F
	0.787	20.00	2.362	3.205	5.331	1.000	1.260	0.020	D3062000M-100F
	0.807	20.50	2.421	3.264	5.390	1.000	1.260	0.016	D3062050M-100F
	0.813	20.64	2.436	3.264	5.390	1.000	1.260	0.015	D3060812I-100F
4xD	0.827	21.00	2.480	3.323	5.449	1.000	1.260	0.012	D3062100M-100F
	0.846	21.50	2.539	3.382	5.508	1.000	1.260	0.008	D3062150M-100F
	0.728	18.50	2.913	3.756	5.882	1.000	1.260	0.035	D4061850M-100F
	0.748	19.00	2.992	3.835	5.961	1.000	1.260	0.031	D4061900M-100F
	0.750	19.05	3.000	3.835	5.961	1.000	1.260	0.031	D4060750I-100F
	0.765	19.43	3.060	3.835	5.961	1.000	1.260	0.028	D4060765I-100F
	0.768	19.50	3.071	3.913	6.039	1.000	1.260	0.028	D4061950M-100F
	0.787	20.00	3.150	3.992	6.118	1.000	1.260	0.020	D4062000M-100F
	0.807	20.50	3.228	4.071	6.197	1.000	1.260	0.016	D4062050M-100F
F	0.813	20.64	3.248	4.071	6.197	1.000	1.260	0.015	D4060812I-100F
	0.827	21.00	3.307	4.150	6.276	1.000	1.260	0.012	D4062100M-100F
	0.846	21.50	3.386	4.228	6.354	1.000	1.260	0.008	D4062150M-100F

IC Inserts

ISO Material	Part No.	Insert Screw	Torx® Driver	Admissible Tightening Torque
P	4T-06T204-P	72251-T7-1	8T-7	7.1 in-lbs (0.8 N-m)
S M	4T-06T204-M			
H	4T-06T204-H			
K	4T-06T204-K			
N	4T-06T204-N			

Expected Hole Tolerances

Length	in	mm
2xD	-.004 / +.008	-.10 / +.20
3xD	-.004 / +.008	-.10 / +.20
4xD	-.004 / +.010	-.10 / +.25

A55: 34 - 35

A55: 31 - 33

A55: 30

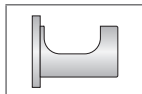
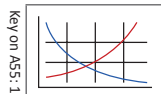

ⓘ = Imperial (in)

Ⓜ = Metric (mm)

IC inserts sold in quantities of 10
Insert screws sold in quantities of 10

4TEX Drill Holders | Metric Shank

06 Series | Diameter Range: 0.728" - 0.866" (18.50 mm - 21.99 mm)

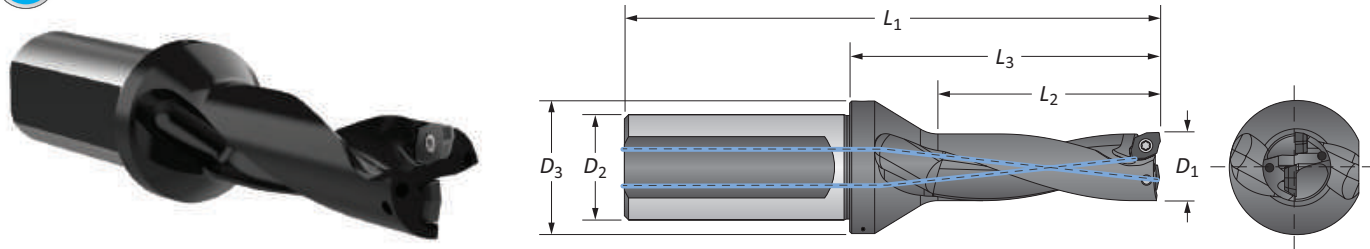

Metric Shank

Length	D ₁		Body			Shank		Max Offset	Part No.
	in	mm	L ₂	L ₃	L ₁	D ₂	D ₃		
2xD	0.728	18.50	37.00	58.40	112.40	25.00	32.00	0.90	D2061850M-25FM
	0.748	19.00	38.00	59.40	113.40	25.00	32.00	0.80	D2061900M-25FM
	0.750	19.05	38.10	59.40	113.40	25.00	32.00	0.80	D2060750I-25FM
	0.765	19.43	38.86	59.41	113.41	25.00	32.00	0.70	D2060765I-25FM
	0.768	19.50	39.00	60.40	114.40	25.00	32.00	0.70	D2061950M-25FM
	0.787	20.00	40.00	61.40	115.40	25.00	32.00	0.50	D2062000M-25FM
	0.807	20.50	41.00	62.40	116.40	25.00	32.00	0.40	D2062050M-25FM
	0.813	20.64	41.25	62.40	116.40	25.00	32.00	0.40	D2060812I-25FM
	0.827	21.00	42.00	63.40	117.40	25.00	32.00	0.30	D2062100M-25FM
0.846	21.50	43.00	64.40	118.40	25.00	32.00	0.20	D2062150M-25FM	
3xD	0.728	18.50	55.00	76.90	130.90	25.00	32.00	0.90	D3061850M-25FM
	0.748	19.00	57.00	78.40	132.40	25.00	32.00	0.80	D3061900M-25FM
	0.750	19.05	57.15	78.40	132.40	25.00	32.00	0.80	D3060750I-25FM
	0.765	19.43	58.29	78.41	132.41	25.00	32.00	0.70	D3060765I-25FM
	0.768	19.50	58.50	79.90	133.90	25.00	32.00	0.70	D3061950M-25FM
	0.787	20.00	60.00	81.40	135.40	25.00	32.00	0.50	D3062000M-25FM
	0.807	20.50	61.50	82.90	136.90	25.00	32.00	0.40	D3062050M-25FM
	0.813	20.64	61.87	82.90	136.90	25.00	32.00	0.40	D3060812I-25FM
	0.827	21.00	63.00	84.40	138.40	25.00	32.00	0.30	D3062100M-25FM
0.846	21.50	64.50	85.90	139.90	25.00	32.00	0.20	D3062150M-25FM	
4xD	0.728	18.50	74.00	95.40	149.40	25.00	32.00	0.90	D4061850M-25FM
	0.748	19.00	76.00	97.40	151.40	25.00	32.00	0.80	D4061900M-25FM
	0.750	19.05	76.20	97.40	151.40	25.00	32.00	0.80	D4060750I-25FM
	0.765	19.43	77.72	97.41	151.41	25.00	32.00	0.70	D4060765I-25FM
	0.768	19.50	78.00	99.40	153.40	25.00	32.00	0.70	D4061950M-25FM
	0.787	20.00	80.00	101.40	155.40	25.00	32.00	0.50	D4062000M-25FM
	0.807	20.50	82.00	103.40	157.40	25.00	32.00	0.40	D4062050M-25FM
	0.813	20.64	82.49	103.40	157.40	25.00	32.00	0.40	D4060812I-25FM
	0.827	21.00	84.00	105.40	159.40	25.00	32.00	0.30	D4062100M-25FM
0.846	21.50	86.00	107.40	161.40	25.00	32.00	0.20	D4062150M-25FM	

IC Inserts

ISO Material	Part No.	Insert Screw	Torx® Driver	Admissible Tightening Torque
P	4T-06T204-P	72251-T7-1	8T-7	7.1 in-lbs (0.8 N-m)
S M	4T-06T204-M			
H	4T-06T204-H			
K	4T-06T204-K			
N	4T-06T204-N			

Expected Hole Tolerances

Length	in	mm
2xD	-.004 / +.008	-.10 / +.20
3xD	-.004 / +.008	-.10 / +.20
4xD	-.004 / +.010	-.10 / +.25

Key on ASS: 1

A55: 34 - 35

A55: 31 - 33

A55: 30

ⓘ = Imperial (in)
 ⓘ = Metric (mm)

IC inserts sold in quantities of 10
 Insert screws sold in quantities of 10

4TEX Drill Holders | Imperial Shank

07 Series | Diameter Range: 0.867" - 1.043" (22.00 mm - 26.49 mm)

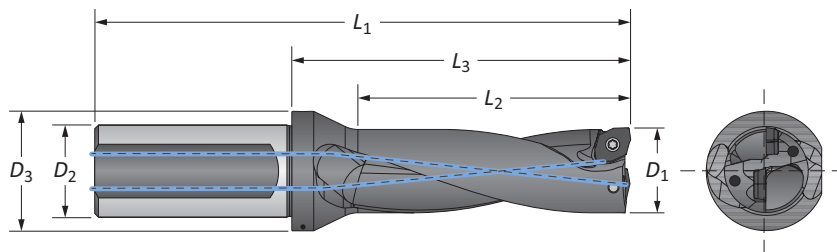

Imperial Shank

Length	D ₁		Body			Shank		Max Offset	Part No.
	in	mm	L ₂	L ₃	L ₁	D ₂	D ₃		
2xD	0.866	22.00	1.732	2.555	4.681	1.000	1.299	0.047	D2072200M-100F
	0.875	22.22	1.750	2.555	4.681	1.000	1.299	0.043	D2070875I-100F
	0.886	22.50	1.772	2.594	4.720	1.000	1.299	0.039	D2072250M-100F
	0.906	23.00	1.811	2.634	4.760	1.000	1.299	0.035	D2072300M-100F
	0.925	23.50	1.850	2.673	4.799	1.000	1.299	0.031	D2072350M-100F
	0.937	23.81	1.874	2.673	4.799	1.000	1.299	0.292	D2070937I-100F
	0.945	24.00	1.890	2.713	4.839	1.000	1.299	0.028	D2072400M-100F
	0.965	24.50	1.929	2.752	4.878	1.000	1.299	0.020	D2072450M-100F
	0.984	25.00	1.969	2.791	4.917	1.000	1.299	0.016	D2072500M-100F
	1.000	25.40	2.000	2.791	4.917	1.000	1.299	0.013	D2071000I-100F
3xD	1.004	25.50	2.008	2.831	4.957	1.000	1.299	0.012	D2072550M-100F
	1.024	26.00	2.047	2.870	4.996	1.000	1.299	0.008	D2072600M-100F
	0.866	22.00	2.598	3.421	5.547	1.000	1.299	0.047	D3072200M-100F
	0.875	22.22	2.625	3.421	5.547	1.000	1.299	0.043	D3070875I-100F
	0.886	22.50	2.657	3.480	5.606	1.000	1.299	0.039	D3072250M-100F
	0.906	23.00	2.717	3.539	5.665	1.000	1.299	0.035	D3072300M-100F
	0.925	23.50	2.776	3.598	5.724	1.000	1.299	0.031	D3072350M-100F
	0.937	23.81	2.811	3.598	5.724	1.000	1.299	0.292	D3070937I-100F
	0.945	24.00	2.835	3.657	5.783	1.000	1.299	0.028	D3072400M-100F
	0.965	24.50	2.894	3.717	5.843	1.000	1.299	0.020	D3072450M-100F
4xD	0.984	25.00	2.953	3.776	5.902	1.000	1.299	0.016	D3072500M-100F
	1.000	25.40	3.000	3.776	5.902	1.000	1.299	0.013	D3071000I-100F
	1.004	25.50	3.012	3.835	5.961	1.000	1.299	0.012	D3072550M-100F
	1.024	26.00	3.071	3.894	6.020	1.000	1.299	0.008	D3072600M-100F
	0.866	22.00	3.465	4.287	6.413	1.000	1.299	0.047	D4072200M-100F
	0.875	22.22	3.500	4.287	6.413	1.000	1.299	0.043	D4070875I-100F
	0.886	22.50	3.543	4.366	6.492	1.000	1.299	0.039	D4072250M-100F
	0.906	23.00	3.622	4.445	6.571	1.000	1.299	0.035	D4072300M-100F
	0.925	23.50	3.701	4.524	6.650	1.000	1.299	0.031	D4072350M-100F
	0.937	23.81	3.748	4.524	6.650	1.000	1.299	0.292	D4070937I-100F
4xD	0.945	24.00	3.780	4.602	6.728	1.000	1.299	0.028	D4072400M-100F
	0.965	24.50	3.858	4.681	6.807	1.000	1.299	0.020	D4072450M-100F
	0.984	25.00	3.937	4.760	6.886	1.000	1.299	0.016	D4072500M-100F
	1.000	25.40	4.000	4.760	6.886	1.000	1.299	0.013	D4071000I-100F
	1.004	25.50	4.016	4.839	6.965	1.000	1.299	0.012	D4072550M-100F
	1.024	26.00	4.094	4.917	7.043	1.000	1.299	0.008	D4072600M-100F

IC Inserts

ISO Material	Part No.	Insert Screw	Torx® Driver	Admissible Tightening Torque
P	4T-070305-P	72568-T8-1	8T-8	10.6 in-lbs (1.2 N-m)
S M	4T-070305-M			
H	4T-070305-H			
K	4T-070305-K			
N	4T-070305-N			

Expected Hole Tolerances

Length	in	mm
2xD	-.004 / +.008	-.10 / +.20
3xD	-.004 / +.008	-.10 / +.20
4xD	-.004 / +.010	-.10 / +.25

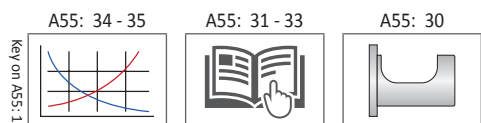

ⓘ = Imperial (in)
Ⓜ = Metric (mm)

IC inserts sold in quantities of 10
Insert screws sold in quantities of 10

4TEX Drill Holders | Metric Shank

07 Series | Diameter Range: 0.867" - 1.043" (22.00 mm - 26.49 mm)

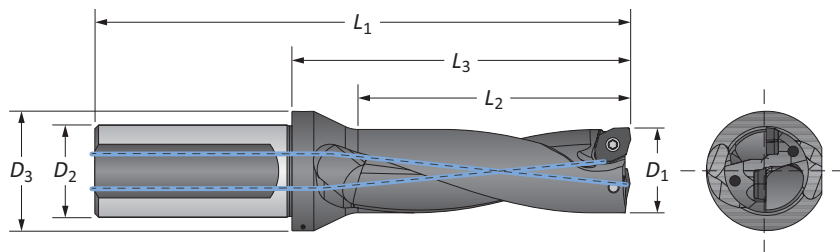

Metric Shank

Length	D ₁		Body			Shank		Max Offset	Part No.
	in	mm	L ₂	L ₃	L ₁	D ₂	D ₃		
2xD	0.866	22.00	44.00	64.90	118.90	25.00	33.00	1.20	D2072200M-25FM
	0.875	22.22	44.45	64.90	118.90	25.00	33.00	1.10	D2070875I-25FM
	0.886	22.50	45.00	65.90	119.90	25.00	33.00	1.00	D2072250M-25FM
	0.906	23.00	46.00	66.90	120.90	25.00	33.00	0.90	D2072300M-25FM
	0.925	23.50	47.00	67.90	121.90	25.00	33.00	0.80	D2072350M-25FM
	0.937	23.81	47.60	67.90	121.90	25.00	33.00	7.40	D2070937I-25FM
	0.945	24.00	48.00	68.90	122.90	25.00	33.00	0.70	D2072400M-25FM
	0.965	24.50	49.00	69.90	123.90	25.00	33.00	0.50	D2072450M-25FM
	0.984	25.00	50.00	70.90	124.90	25.00	33.00	0.40	D2072500M-25FM
	1.000	25.40	50.80	70.90	124.90	25.00	33.00	0.30	D2071000I-25FM
3xD	1.004	25.50	51.00	71.90	125.90	25.00	33.00	0.30	D2072550M-25FM
	1.024	26.00	52.00	72.90	126.90	25.00	33.00	0.20	D2072600M-25FM
	0.866	22.00	66.00	86.90	140.90	25.00	33.00	1.20	D3072200M-25FM
	0.875	22.22	66.68	86.90	140.90	25.00	33.00	1.10	D3070875I-25FM
	0.886	22.50	67.50	88.40	142.40	25.00	33.00	1.00	D3072250M-25FM
	0.906	23.00	69.00	89.90	143.90	25.00	33.00	0.90	D3072300M-25FM
	0.925	23.50	70.50	91.40	145.40	25.00	33.00	0.80	D3072350M-25FM
	0.937	23.81	71.40	91.40	145.40	25.00	33.00	7.40	D3070937I-25FM
	0.945	24.00	72.00	92.90	146.90	25.00	33.00	0.70	D3072400M-25FM
	0.965	24.50	73.50	94.40	148.40	25.00	33.00	0.50	D3072450M-25FM
4xD	0.984	25.00	75.00	95.90	149.90	25.00	33.00	0.40	D3072500M-25FM
	1.000	25.40	76.20	95.90	149.90	25.00	33.00	0.30	D3071000I-25FM
	1.004	25.50	76.50	97.00	151.00	25.00	33.00	0.30	D3072550M-25FM
	1.024	26.00	78.00	99.00	153.00	25.00	33.00	0.20	D3072600M-25FM
	0.866	22.00	88.00	109.00	163.00	25.00	33.00	1.20	D4072200M-25FM
	0.875	22.22	88.90	108.90	162.90	25.00	33.00	1.10	D4070875I-25FM
	0.886	22.50	90.00	111.00	165.00	25.00	33.00	1.00	D4072250M-25FM
	0.906	23.00	92.00	113.00	167.00	25.00	33.00	0.90	D4072300M-25FM
	0.925	23.50	94.00	115.00	169.00	25.00	33.00	0.80	D4072350M-25FM
	0.937	23.81	95.20	114.90	168.90	25.00	33.00	7.40	D4070937I-25FM
4xD	0.945	24.00	96.00	117.00	171.00	25.00	33.00	0.70	D4072400M-25FM
	0.965	24.50	98.00	119.00	173.00	25.00	33.00	0.50	D4072450M-25FM
	0.984	25.00	100.00	121.00	175.00	25.00	33.00	0.40	D4072500M-25FM
	1.000	25.40	101.60	120.90	174.90	25.00	33.00	0.30	D4071000I-25FM
	1.004	25.50	102.00	123.00	177.00	25.00	33.00	0.30	D4072550M-25FM
	1.024	26.00	104.00	125.00	179.00	25.00	33.00	0.20	D4072600M-25FM

IC Inserts

ISO Material	Part No.	Insert Screw	Torx® Driver	Admissible Tightening Torque
P	4T-070305-P	72568-T8-1	8T-8	10.6 in-lbs (1.2 N-m)
S M	4T-070305-M			
H	4T-070305-H			
K	4T-070305-K			
N	4T-070305-N			

Expected Hole Tolerances

Length	in	mm
2xD	-.004 / +.008	-.10 / +.20
3xD	-.004 / +.008	-.10 / +.20
4xD	-.004 / +.010	-.10 / +.25

Key on ASS: 1

A55: 34 - 35

A55: 31 - 33

A55: 30

ⓘ = Imperial (in)
 ⓘ = Metric (mm)

IC inserts sold in quantities of 10
 Insert screws sold in quantities of 10

4TEX Drill Holders | Imperial Shank

09 Series | Diameter Range: 1.044" - 1.259" (26.50 mm - 31.99 mm)

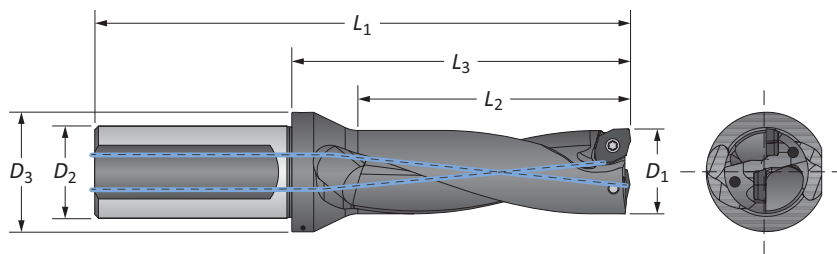

Imperial Shank

Length	D ₁		Body			Shank		Max Offset	Part No.
	in	mm	L ₂	L ₃	L ₁	D ₂	D ₃		
2xD	1.043	26.50	2.087	2.980	5.303	1.250	1.614	0.066	D2092650M-125F
	1.063	27.00	2.126	3.020	5.343	1.250	1.614	0.063	D2092700M-125F
	1.083	27.50	2.165	3.059	5.382	1.250	1.614	0.057	D2092750M-125F
	1.102	28.00	2.205	3.098	5.421	1.250	1.614	0.051	D2092800M-125F
	1.122	28.50	2.244	3.138	5.461	1.250	1.614	0.048	D2092850M-125F
	1.125	28.58	2.250	3.138	5.461	1.250	1.614	0.046	D2091125I-125F
	1.142	29.00	2.283	3.177	5.500	1.250	1.614	0.043	D2092900M-125F
	1.161	29.50	2.323	3.217	5.539	1.250	1.693	0.038	D2092950M-125F
	1.181	30.00	2.362	3.256	5.579	1.250	1.693	0.031	D2093000M-125F
	1.187	30.15	2.374	3.256	5.579	1.250	1.693	0.032	D2091187I-125F
	1.201	30.50	2.402	3.295	5.618	1.250	1.693	0.029	D2093050M-125F
	1.220	31.00	2.441	3.335	5.657	1.250	1.693	0.024	D2093100M-125F
1.240	31.50	2.480	3.374	5.697	1.250	1.693	0.020	D2093150M-125F	
1.250	31.75	2.500	3.374	5.697	1.250	1.693	0.019	D2091250I-125F	
3xD	1.043	26.50	3.130	4.024	6.346	1.250	1.614	0.066	D3092650M-125F
	1.063	27.00	3.189	4.083	6.406	1.250	1.614	0.063	D3092700M-125F
	1.083	27.50	3.248	4.142	6.465	1.250	1.614	0.057	D3092750M-125F
	1.102	28.00	3.307	4.201	6.524	1.250	1.614	0.051	D3092800M-125F
	1.122	28.50	3.366	4.260	6.583	1.250	1.614	0.048	D3092850M-125F
	1.125	28.58	3.375	4.260	6.583	1.250	1.614	0.046	D3091125I-125F
	1.142	29.00	3.425	4.319	6.642	1.250	1.614	0.043	D3092900M-125F
	1.161	29.50	3.484	4.378	6.701	1.250	1.693	0.038	D3092950M-125F
	1.181	30.00	3.543	4.437	6.760	1.250	1.693	0.031	D3093000M-125F
	1.187	30.15	3.561	4.437	6.760	1.250	1.693	0.032	D3091187I-125F
	1.201	30.50	3.602	4.496	6.819	1.250	1.693	0.029	D3093050M-125F
	1.220	31.00	3.661	4.555	6.878	1.250	1.693	0.024	D3093100M-125F
1.240	31.50	3.720	4.614	6.937	1.250	1.693	0.020	D3093150M-125F	
1.250	31.75	3.750	4.614	6.937	1.250	1.693	0.019	D3091250I-125F	

IC Inserts

ISO Material	Part No.	Insert Screw	Torx® Driver	Admissible Tightening Torque
P	4T-09T306-P	738-T10-1	8T-10	17.7 in-lbs (2.0 N-m)
S	4T-09T306-M			
H	4T-09T306-H			
K	4T-09T306-K			
N	4T-09T306-N			

Expected Hole Tolerances

Length	in	mm
2xD	-.006 / +.010	-.15 / +.25
3xD	-.006 / +.010	-.15 / +.25
4xD	-.006 / +.012	-.15 / +.30

A55: 34 - 35

A55: 31 - 33

A55: 30

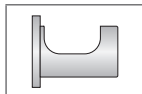
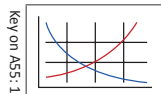

ⓘ = Imperial (in)
Ⓜ = Metric (mm)

IC inserts sold in quantities of 10
Insert screws sold in quantities of 10

4TEX Drill Holders | Imperial Shank

09 Series | Diameter Range: 1.044" - 1.259" (26.50 mm - 31.99 mm)

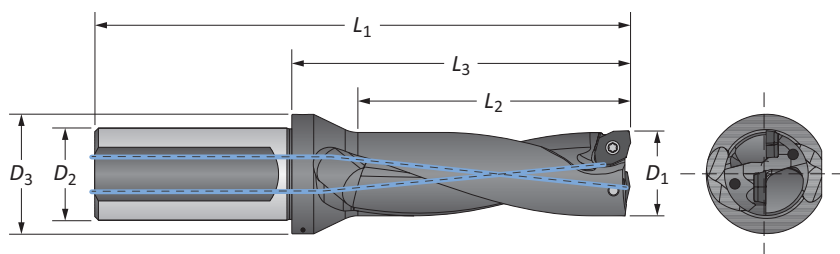

Imperial Shank

Length	D ₁		Body			Shank		Max Offset	Part No.
	in	mm	L ₂	L ₃	L ₁	D ₂	D ₃		
i 4xD	1.043	26.50	4.173	5.067	7.390	1.250	1.614	0.066	D4092650M-125F
	1.063	27.00	4.252	5.146	7.469	1.250	1.614	0.063	D4092700M-125F
	1.083	27.50	4.331	5.224	7.547	1.250	1.614	0.057	D4092750M-125F
	1.102	28.00	4.409	5.303	7.626	1.250	1.614	0.051	D4092800M-125F
	1.122	28.50	4.488	5.382	7.705	1.250	1.614	0.048	D4092850M-125F
	1.125	28.58	4.500	5.382	7.705	1.250	1.614	0.046	D4091125I-125F
	1.142	29.00	4.567	5.461	7.783	1.250	1.614	0.043	D4092900M-125F
	1.161	29.50	4.646	5.539	7.862	1.250	1.693	0.038	D4092950M-125F
	1.181	30.00	4.724	5.618	7.941	1.250	1.693	0.031	D4093000M-125F
	1.187	30.15	4.748	5.618	7.941	1.250	1.693	0.032	D4091187I-125F
	1.201	30.50	4.803	5.697	8.020	1.250	1.693	0.029	D4093050M-125F
	1.220	31.00	4.882	5.776	8.098	1.250	1.693	0.024	D4093100M-125F
	1.240	31.50	4.961	5.854	8.177	1.250	1.693	0.020	D4093150M-125F
1.250	31.75	5.000	5.854	8.177	1.250	1.693	0.019	D4091250I-125F	

IC Inserts

ISO Material	Part No.	Insert Screw	Torx® Driver	Admissible Tightening Torque
P	4T-09T306-P	738-T10-1	8T-10	17.7 in-lbs (2.0 N-m)
S M	4T-09T306-M			
H	4T-09T306-H			
K	4T-09T306-K			
N	4T-09T306-N			

Expected Hole Tolerances

Length	in	mm
2xD	-.006 / +.010	-.15 / +.25
3xD	-.006 / +.010	-.15 / +.25
4xD	-.006 / +.012	-.15 / +.30

Key on ASS: 1

A55: 34 - 35

A55: 31 - 33

A55: 30

i = Imperial (in)
m = Metric (mm)

IC inserts sold in quantities of 10
Insert screws sold in quantities of 10

4TEX Drill Holders | Metric Shank

09 Series | Diameter Range: 1.044" - 1.259" (26.50 mm - 31.99 mm)

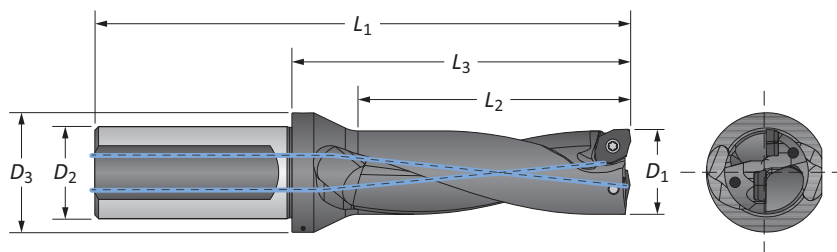

Metric Shank

Length	D ₁		Body			Shank		Max Offset	Part No.
	in	mm	L ₂	L ₃	L ₁	D ₂	D ₃		
2xD	1.043	26.50	53.00	75.70	134.70	32.00	41.00	1.68	D2092650M-32FM
	1.063	27.00	54.00	76.70	135.70	32.00	41.00	1.60	D2092700M-32FM
	1.083	27.50	55.00	77.70	136.70	32.00	41.00	1.45	D2092750M-32FM
	1.102	28.00	56.00	78.70	137.70	32.00	41.00	1.30	D2092800M-32FM
	1.122	28.50	57.00	79.70	138.70	32.00	41.00	1.21	D2092850M-32FM
	1.125	28.58	57.15	79.70	138.70	32.00	41.00	1.20	D2091125I-32FM
	1.142	29.00	58.00	80.70	139.70	32.00	41.00	1.10	D2092900M-32FM
	1.161	29.50	59.00	81.70	140.70	32.00	43.00	0.97	D2092950M-32FM
	1.181	30.00	60.00	82.70	141.70	32.00	43.00	0.80	D2093000M-32FM
	1.187	30.15	60.30	82.70	141.70	32.00	43.00	0.82	D2091187I-32FM
	1.201	30.50	61.00	83.70	142.70	32.00	43.00	0.74	D2093050M-32FM
	1.220	31.00	62.00	84.70	143.70	32.00	43.00	0.60	D2093100M-32FM
3xD	1.240	31.50	63.00	85.70	144.70	32.00	43.00	0.50	D2093150M-32FM
	1.250	31.75	63.50	85.70	144.70	32.00	43.00	0.50	D2091250I-32FM
	1.043	26.50	79.50	102.20	161.20	32.00	41.00	1.68	D3092650M-32FM
	1.063	27.00	81.00	103.70	162.70	32.00	41.00	1.60	D3092700M-32FM
	1.083	27.50	82.50	105.20	164.20	32.00	41.00	1.45	D3092750M-32FM
	1.102	28.00	84.00	106.70	165.70	32.00	41.00	1.30	D3092800M-32FM
	1.122	28.50	85.50	108.20	167.20	32.00	41.00	1.21	D3092850M-32FM
	1.125	28.58	85.73	108.20	167.20	32.00	41.00	1.20	D3091125I-32FM
	1.142	29.00	87.00	109.70	168.70	32.00	41.00	1.10	D3092900M-32FM
	1.161	29.50	88.50	111.20	170.20	32.00	43.00	0.97	D3092950M-32FM
	1.181	30.00	90.00	112.70	171.70	32.00	43.00	0.80	D3093000M-32FM
	1.187	30.15	90.45	112.70	171.70	32.00	43.00	0.82	D3091187I-32FM
1.201	30.50	91.50	114.20	173.20	32.00	43.00	0.74	D3093050M-32FM	
1.220	31.00	93.00	115.70	174.70	32.00	43.00	0.60	D3093100M-32FM	
1.240	31.50	94.50	117.00	176.20	32.00	43.00	0.50	D3093150M-32FM	
1.250	31.75	95.25	117.20	176.20	32.00	43.00	0.50	D3091250I-32FM	

IC Inserts

ISO Material	Part No.	Insert Screw	Torx® Driver	Admissible Tightening Torque
P	4T-09T306-P	738-T10-1	8T-10	17.7 in-lbs (2.0 N-m)
S	4T-09T306-M			
H	4T-09T306-H			
K	4T-09T306-K			
N	4T-09T306-N			

Expected Hole Tolerances

Length	in	mm
2xD	-.006 / +.010	-.15 / +.25
3xD	-.006 / +.010	-.15 / +.25
4xD	-.006 / +.012	-.15 / +.30

A55: 34 - 35

A55: 31 - 33

A55: 30

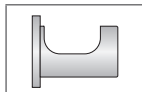
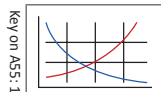

i = Imperial (in)
m = Metric (mm)

IC inserts sold in quantities of 10
Insert screws sold in quantities of 10

4TEX Drill Holders | Metric Shank

09 Series | Diameter Range: 1.044" - 1.259" (26.50 mm - 31.99 mm)

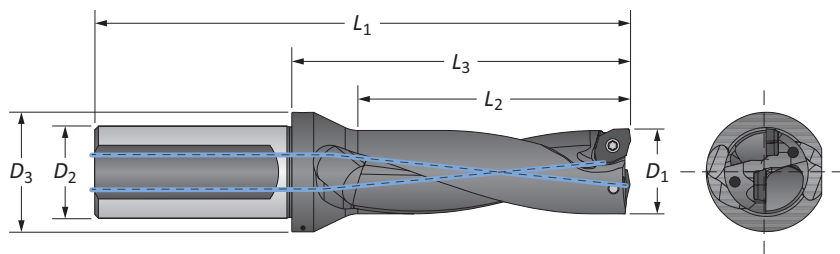

Metric Shank

Length	D ₁		Body			Shank		Max Offset	Part No.
	in	mm	L ₂	L ₃	L ₁	D ₂	D ₃		
4xD	1.043	26.50	106.00	128.70	187.70	32.00	41.00	1.68	D4092650M-32FM
	1.063	27.00	108.00	130.70	189.70	32.00	41.00	1.60	D4092700M-32FM
	1.083	27.50	110.00	132.70	191.70	32.00	41.00	1.45	D4092750M-32FM
	1.102	28.00	112.00	134.70	193.70	32.00	41.00	1.30	D4092800M-32FM
	1.122	28.50	114.00	136.70	195.70	32.00	41.00	1.21	D4092850M-32FM
	1.125	28.58	114.30	136.70	195.70	32.00	41.00	1.20	D4091125I-32FM
	1.142	29.00	116.00	138.70	197.70	32.00	41.00	1.10	D4092900M-32FM
	1.161	29.50	118.00	140.70	199.70	32.00	43.00	0.97	D4092950M-32FM
	1.181	30.00	120.00	142.70	201.70	32.00	43.00	0.80	D4093000M-32FM
	1.187	30.15	120.60	142.70	201.70	32.00	43.00	0.82	D4091187I-32FM
	1.201	30.50	122.00	144.70	203.70	32.00	43.00	0.74	D4093050M-32FM
	1.220	31.00	124.00	146.70	205.70	32.00	43.00	0.60	D4093100M-32FM
	1.240	31.50	126.00	148.70	207.70	32.00	43.00	0.50	D4093150M-32FM
1.250	31.75	127.00	148.70	207.70	32.00	43.00	0.50	D4091250I-32FM	

IC Inserts

ISO Material	Part No.	Insert Screw	Torx® Driver	Admissible Tightening Torque
P	4T-09T306-P	738-T10-1	8T-10	17.7 in-lbs (2.0 N-m)
S M	4T-09T306-M			
H	4T-09T306-H			
K	4T-09T306-K			
N	4T-09T306-N			

Expected Hole Tolerances

Length	in	mm
2xD	-.006 / +.010	-.15 / +.25
3xD	-.006 / +.010	-.15 / +.25
4xD	-.006 / +.012	-.15 / +.30

Key on ASS: 1

A55: 34 - 35

A55: 31 - 33

A55: 30

ⓘ = Imperial (in)
 ⓘ = Metric (mm)

IC inserts sold in quantities of 10
 Insert screws sold in quantities of 10

4TEX Drill Holders | Imperial Shank

11 Series | Diameter Range: 1.260" - 1.535" (32.00 mm - 38.99 mm)

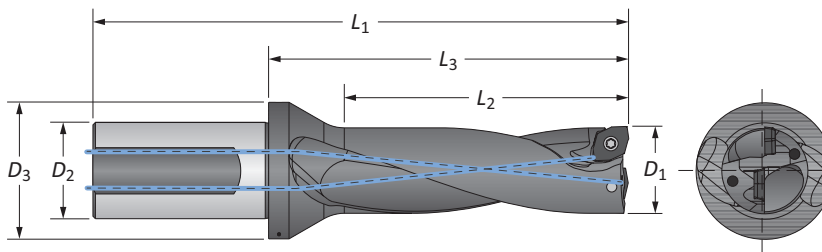

Imperial Shank

Length	D ₁		Body			Shank		Max Offset	Part No.
	in	mm	L ₂	L ₃	L ₁	D ₂	D ₃		
2xD	1.260	32.00	2.520	3.953	6.669	1.500	2.126	0.087	D2113200M-150F
	1.280	32.50	2.559	3.953	6.669	1.500	2.126	0.081	D2113250M-150F
	1.299	33.00	2.598	4.031	6.748	1.500	2.126	0.075	D2113300M-150F
	1.312	33.32	2.624	4.031	6.748	1.500	2.126	0.073	D2111312I-150F
	1.319	33.50	2.638	4.031	6.748	1.500	2.126	0.071	D2113350M-150F
	1.339	34.00	2.677	4.110	6.827	1.500	2.126	0.067	D2113400M-150F
	1.358	34.50	2.717	4.110	6.827	1.500	2.126	0.061	D2113450M-150F
	1.375	34.92	2.750	4.110	6.827	1.500	2.126	0.056	D2111375I-150F
	1.378	35.00	2.756	4.189	6.906	1.500	2.126	0.055	D2113500M-150F
	1.398	35.50	2.795	4.189	6.906	1.500	2.126	0.051	D2113550M-150F
	1.417	36.00	2.835	4.268	6.984	1.500	2.126	0.047	D2113600M-150F
	1.437	36.50	2.874	4.268	6.984	1.500	2.126	0.042	D2113650M-150F
	1.457	37.00	2.913	4.346	7.063	1.500	2.126	0.035	D2113700M-150F
	1.476	37.50	2.953	4.346	7.063	1.500	2.126	0.032	D2113750M-150F
	1.496	38.00	2.992	4.425	7.142	1.500	2.126	0.028	D2113800M-150F
1.500	38.10	3.000	4.425	7.142	1.500	2.126	0.027	D2111500I-150F	
1.516	38.50	3.031	4.425	7.142	1.500	2.126	0.022	D2113850M-150F	
3xD	1.260	32.00	3.780	5.213	7.929	1.500	2.126	0.087	D3113200M-150F
	1.280	32.50	3.839	5.213	7.929	1.500	2.126	0.081	D3113250M-150F
	1.299	33.00	3.898	5.331	8.047	1.500	2.126	0.075	D3113300M-150F
	1.312	33.32	3.936	5.331	8.047	1.500	2.126	0.073	D3111312I-150F
	1.319	33.50	3.957	5.331	8.047	1.500	2.126	0.071	D3113350M-150F
	1.339	34.00	4.016	5.449	8.165	1.500	2.126	0.067	D3113400M-150F
	1.358	34.50	4.075	5.449	8.165	1.500	2.126	0.061	D3113450M-150F
	1.375	34.92	4.125	5.449	8.165	1.500	2.126	0.056	D3111375I-150F
	1.378	35.00	4.134	5.567	8.283	1.500	2.126	0.055	D3113500M-150F
	1.398	35.50	4.193	5.567	8.283	1.500	2.126	0.051	D3113550M-150F
	1.417	36.00	4.252	5.685	8.402	1.500	2.126	0.047	D3113600M-150F
	1.437	36.50	4.311	5.685	8.402	1.500	2.126	0.042	D3113650M-150F
	1.457	37.00	4.370	5.803	8.520	1.500	2.126	0.035	D3113700M-150F
	1.476	37.50	4.429	5.803	8.520	1.500	2.126	0.032	D3113750M-150F
	1.496	38.00	4.488	5.921	8.638	1.500	2.126	0.028	D3113800M-150F
1.500	38.10	4.500	5.921	8.638	1.500	2.126	0.027	D3111500I-150F	
1.516	38.50	4.547	5.921	8.638	1.500	2.126	0.022	D3113850M-150F	

IC Inserts

ISO Material	Part No.	Insert Screw	Torx® Driver	Admissible Tightening Torque
P	4T-11T306-P	7488-T15-1	8T-15	30.9 in-lbs (3.5 N-m)
S M	4T-11T306-M			
H	4T-11T306-H			
K	4T-11T306-K			
N	4T-11T306-N			

Expected Hole Tolerances

Length	in	mm
2xD	-.006 / +.010	-.15 / +.25
3xD	-.006 / +.010	-.15 / +.25
4xD	-.006 / +.012	-.15 / +.30

A55: 34 - 35 A55: 31 - 33 A55: 30

ⓘ = Imperial (in)
Ⓜ = Metric (mm)

IC inserts sold in quantities of 10
Insert screws sold in quantities of 10

4TEX Drill Holders | Imperial Shank

11 Series | Diameter Range: 1.260" - 1.535" (32.00 mm - 38.99 mm)

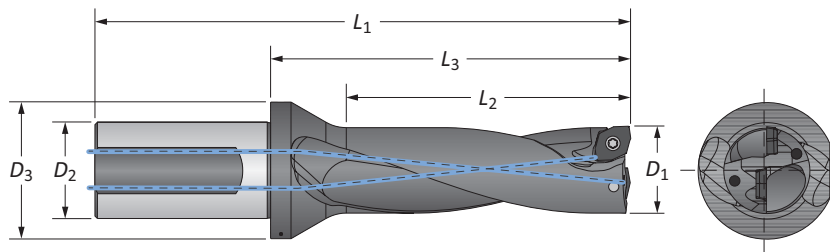

Imperial Shank

Length	D ₁		Body			Shank		Max Offset	Part No.
	in	mm	L ₂	L ₃	L ₁	D ₂	D ₃		
4xD	1.260	32.00	5.039	6.079	8.795	1.500	2.126	0.087	D4113200M-150F
	1.280	32.50	5.118	6.079	8.795	1.500	2.126	0.081	D4113250M-150F
	1.299	33.00	5.197	6.236	8.953	1.500	2.126	0.075	D4113300M-150F
	1.312	33.32	5.248	6.236	8.953	1.500	2.126	0.073	D4111312I-150F
	1.319	33.50	5.276	6.236	8.953	1.500	2.126	0.071	D4113350M-150F
	1.339	34.00	5.354	6.394	9.110	1.500	2.126	0.067	D4113400M-150F
	1.358	34.50	5.433	6.394	9.110	1.500	2.126	0.061	D4113450M-150F
	1.375	34.92	5.500	6.394	9.110	1.500	2.126	0.056	D4111375I-150F
	1.378	35.00	5.512	6.551	9.268	1.500	2.126	0.055	D4113500M-150F
	1.398	35.50	5.591	6.551	9.268	1.500	2.126	0.051	D4113550M-150F
	1.417	36.00	5.669	6.709	9.425	1.500	2.126	0.047	D4113600M-150F
	1.437	36.50	5.748	6.709	9.425	1.500	2.126	0.042	D4113650M-150F
	1.457	37.00	5.827	6.866	9.583	1.500	2.126	0.035	D4113700M-150F
	1.476	37.50	5.906	6.866	9.583	1.500	2.126	0.032	D4113750M-150F
	1.496	38.00	5.984	7.024	9.740	1.500	2.126	0.028	D4113800M-150F
1.500	38.10	6.000	7.024	9.740	1.500	2.126	0.027	D4111500I-150F	
1.516	38.50	6.063	7.024	9.740	1.500	2.126	0.022	D4113850M-150F	

IC Inserts

ISO Material	Part No.	Insert Screw	Torx® Driver	Admissible Tightening Torque
P	4T-11T306-P	7488-T15-1	8T-15	30.9 in-lbs (3.5 N-m)
S	4T-11T306-M			
H	4T-11T306-H			
K	4T-11T306-K			
N	4T-11T306-N			

Expected Hole Tolerances

Length	in	mm
2xD	-0.006 / +0.010	-.15 / +.25
3xD	-0.006 / +0.010	-.15 / +.25
4xD	-0.006 / +0.012	-.15 / +.30

A55: 34 - 35 A55: 31 - 33 A55: 30

i = Imperial (in)
m = Metric (mm)

IC inserts sold in quantities of 10
Insert screws sold in quantities of 10

4TEX Drill Holders | Metric Shank

11 Series | Diameter Range: 1.260" - 1.535" (32.00 mm - 38.99 mm)

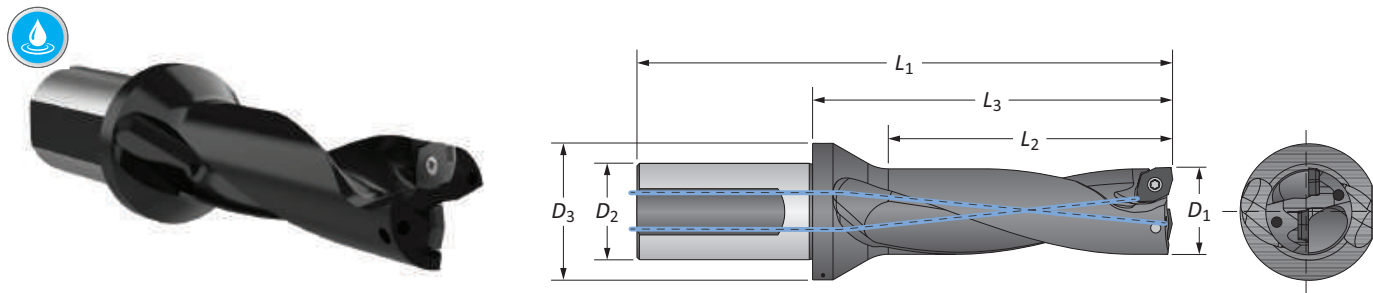

Metric Shank

Length	D ₁		Body			Shank		Max Offset	Part No.
	in	mm	L ₂	L ₃	L ₁	D ₂	D ₃		
2xD	1.260	32.00	64.00	100.40	169.40	40.00	54.00	2.20	D2113200M-40FM
	1.280	32.50	65.00	100.40	169.40	40.00	54.00	2.05	D2113250M-40FM
	1.299	33.00	66.00	102.40	171.40	40.00	54.00	1.90	D2113300M-40FM
	1.312	33.32	66.65	102.40	171.40	40.00	54.00	1.84	D2111312I-40FM
	1.319	33.50	67.00	102.40	171.40	40.00	54.00	1.80	D2113350M-40FM
	1.339	34.00	68.00	104.40	173.40	40.00	54.00	1.70	D2113400M-40FM
	1.358	34.50	69.00	104.40	173.40	40.00	54.00	1.55	D2113450M-40FM
	1.375	34.92	69.85	104.40	173.40	40.00	54.00	1.42	D2111375I-40FM
	1.378	35.00	70.00	106.40	175.40	40.00	54.00	1.40	D2113500M-40FM
	1.398	35.50	71.00	106.40	175.40	40.00	54.00	1.30	D2113550M-40FM
	1.417	36.00	72.00	108.40	177.40	40.00	54.00	1.20	D2113600M-40FM
	1.437	36.50	73.00	108.40	177.40	40.00	54.00	1.06	D2113650M-40FM
	1.457	37.00	74.00	110.40	179.40	40.00	54.00	0.90	D2113700M-40FM
	1.476	37.50	75.00	110.40	179.40	40.00	54.00	0.81	D2113750M-40FM
1.496	38.00	76.00	112.40	181.40	40.00	54.00	0.70	D2113800M-40FM	
1.500	38.10	76.20	112.40	181.40	40.00	54.00	0.69	D2111500I-40FM	
1.516	38.50	77.00	112.40	181.40	40.00	54.00	0.56	D2113850M-40FM	
3xD	1.260	32.00	96.00	132.40	201.40	40.00	54.00	2.20	D3113200M-40FM
	1.280	32.50	97.50	132.40	201.40	40.00	54.00	2.05	D3113250M-40FM
	1.299	33.00	99.00	135.40	204.40	40.00	54.00	1.90	D3113300M-40FM
	1.312	33.32	99.97	135.40	204.40	40.00	54.00	1.84	D3111312I-40FM
	1.319	33.50	100.50	135.40	204.40	40.00	54.00	1.80	D3113350M-40FM
	1.339	34.00	102.00	138.40	207.40	40.00	54.00	1.70	D3113400M-40FM
	1.358	34.50	103.50	138.40	207.40	40.00	54.00	1.55	D3113450M-40FM
	1.375	34.92	104.78	138.40	207.40	40.00	54.00	1.42	D3111375I-40FM
	1.378	35.00	105.00	141.40	210.40	40.00	54.00	1.40	D3113500M-40FM
	1.398	35.50	106.50	141.40	210.40	40.00	54.00	1.30	D3113550M-40FM
	1.417	36.00	108.00	144.40	213.40	40.00	54.00	1.20	D3113600M-40FM
	1.437	36.50	109.50	144.40	213.40	40.00	54.00	1.06	D3113650M-40FM
	1.457	37.00	111.00	147.40	216.40	40.00	54.00	0.90	D3113700M-40FM
	1.476	37.50	112.50	147.40	216.40	40.00	54.00	0.81	D3113750M-40FM
1.496	38.00	114.00	150.40	219.40	40.00	54.00	0.70	D3113800M-40FM	
1.500	38.10	114.30	150.40	219.40	40.00	54.00	0.69	D3111500I-40FM	
1.516	38.50	115.50	150.40	219.40	40.00	54.00	0.56	D3113850M-150F	

IC Inserts

ISO Material	Part No.	Insert Screw	Torx® Driver	Admissible Tightening Torque
P	4T-11T306-P	7488-T15-1	8T-15	30.9 in-lbs (3.5 N-m)
S	4T-11T306-M			
H	4T-11T306-H			
K	4T-11T306-K			
N	4T-11T306-N			

Expected Hole Tolerances

Length	in	mm
2xD	-.006 / +.010	-.15 / +.25
3xD	-.006 / +.010	-.15 / +.25
4xD	-.006 / +.012	-.15 / +.30

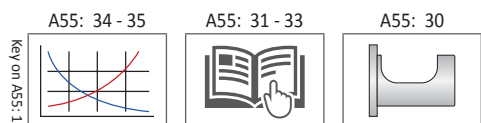

i = Imperial (in)
m = Metric (mm)

IC inserts sold in quantities of 10
Insert screws sold in quantities of 10

4TEX Drill Holders | Metric Shank

11 Series | Diameter Range: 1.260" - 1.535" (32.00 mm - 38.99 mm)

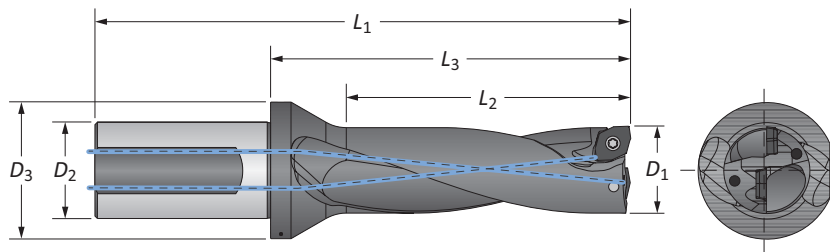

Metric Shank

Length	D ₁		Body			Shank		Max Offset	Part No.
	in	mm	L ₂	L ₃	L ₁	D ₂	D ₃		
m 4xD	1.260	32.00	128.00	154.40	223.40	40.00	54.00	2.20	D4113200M-40FM
	1.280	32.50	130.00	154.40	223.40	40.00	54.00	2.05	D4113250M-40FM
	1.299	33.00	132.00	158.40	227.40	40.00	54.00	1.90	D4113300M-40FM
	1.312	33.32	133.30	158.40	227.40	40.00	54.00	1.84	D4111312I-40FM
	1.319	33.50	134.00	158.40	227.40	40.00	54.00	1.80	D4113350M-40FM
	1.339	34.00	136.00	162.40	231.40	40.00	54.00	1.70	D4113400M-40FM
	1.358	34.50	138.00	162.40	231.40	40.00	54.00	1.55	D4113450M-40FM
	1.375	34.92	139.70	162.40	231.40	40.00	54.00	1.42	D4111375I-40FM
	1.378	35.00	140.00	166.40	235.40	40.00	54.00	1.40	D4113500M-40FM
	1.398	35.50	142.00	166.40	235.40	40.00	54.00	1.30	D4113550M-40FM
	1.417	36.00	144.00	170.40	239.40	40.00	54.00	1.20	D4113600M-40FM
	1.437	36.50	146.00	170.40	239.40	40.00	54.00	1.06	D4113650M-40FM
	1.457	37.00	148.00	174.40	243.40	40.00	54.00	0.90	D4113700M-40FM
	1.476	37.50	150.00	174.40	243.40	40.00	54.00	0.81	D4113750M-40FM
	1.496	38.00	152.00	178.40	247.40	40.00	54.00	0.70	D4113800M-40FM
1.500	38.10	152.40	178.40	247.40	40.00	54.00	0.69	D4111500I-40FM	
1.516	38.50	154.00	178.40	247.40	40.00	54.00	0.56	D4113850M-40FM	

IC Inserts

ISO Material	Part No.	Insert Screw	Torx® Driver	Admissible Tightening Torque
P	4T-11T306-P	7488-T15-1	8T-15	30.9 in-lbs (3.5 N-m)
S M	4T-11T306-M			
H	4T-11T306-H			
K	4T-11T306-K			
N	4T-11T306-N			

Expected Hole Tolerances

Length	in	mm
2xD	-.006 / +.010	-.15 / +.25
3xD	-.006 / +.010	-.15 / +.25
4xD	-.006 / +.012	-.15 / +.30

Key on ASS: 1

A55: 34 - 35 A55: 31 - 33 A55: 30

i = Imperial (in)
m = Metric (mm)

IC inserts sold in quantities of 10
Insert screws sold in quantities of 10

4TEX Drill Holders | Imperial Shank

14 Series | Diameter Range: 1.536" - 1.850" (39.00 mm - 47.00 mm)

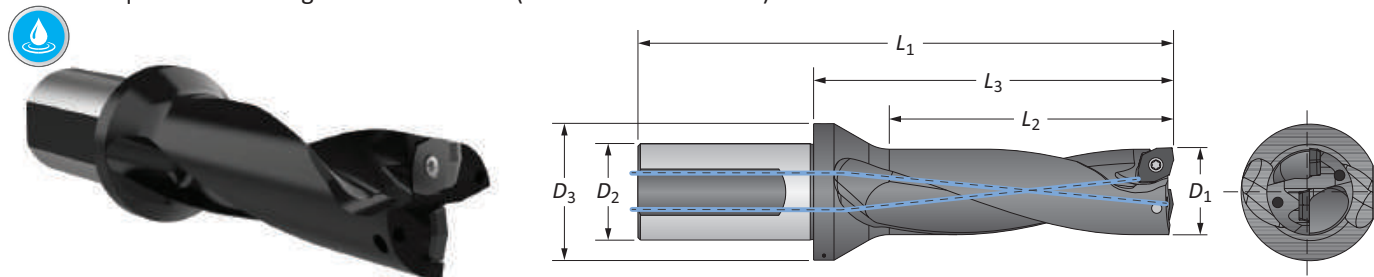

Imperial Shank

Length	D ₁		Body			Shank		Max Offset	Part No.
	in	mm	L ₂	L ₃	L ₁	D ₂	D ₃		
2xD	1.535	39.00	3.071	4.346	7.063	1.500	2.126	0.110	D2143900M-150F
	1.555	39.50	3.110	4.346	7.063	1.500	2.126	0.105	D2143950M-150F
	1.562	39.67	3.124	4.346	7.063	1.500	2.126	0.103	D2141562I-150F
	1.575	40.00	3.150	4.425	7.142	1.500	2.126	0.098	D2144000M-150F
	1.594	40.50	3.189	4.425	7.142	1.500	2.126	0.095	D2144050M-150F
	1.614	41.00	3.228	4.504	7.220	1.500	2.126	0.091	D2144100M-150F
	1.625	41.28	3.250	4.504	7.220	1.500	2.126	0.088	D2141625I-150F
	1.634	41.50	3.268	4.504	7.220	1.500	2.126	0.085	D2144150M-150F
	1.654	42.00	3.307	4.583	7.299	1.500	2.126	0.079	D2144200M-150F
	1.673	42.50	3.346	4.583	7.299	1.500	2.126	0.075	D2144250M-150F
	1.687	42.85	3.374	4.583	7.299	1.500	2.126	0.072	D2141687I-150F
	1.693	43.00	3.386	4.661	7.378	1.500	2.323	0.071	D2144300M-150F
	1.713	43.50	3.425	4.661	7.378	1.500	2.323	0.065	D2144350M-150F
	1.732	44.00	3.465	4.740	7.457	1.500	2.323	0.059	D2144400M-150F
	1.750	44.45	3.500	4.740	7.457	1.500	2.323	0.055	D2141750I-150F
	1.752	44.50	3.504	4.740	7.457	1.500	2.323	0.055	D2144450M-150F
	1.772	45.00	3.543	4.819	7.535	1.500	2.323	0.051	D2144500M-150F
	1.791	45.50	3.583	4.819	7.535	1.500	2.323	0.045	D2144550M-150F
1.812	46.02	3.624	4.898	7.614	1.500	2.323	0.040	D2141812I-150F	
1.811	46.00	3.622	4.898	7.614	1.500	2.323	0.039	D2144600M-150F	
1.831	46.50	3.661	4.898	7.614	1.500	2.323	0.036	D2144650M-150F	
1.850	47.00	3.701	4.976	7.693	1.500	2.323	0.031	D2144700M-150F	
3xD	1.535	39.00	4.606	5.882	8.598	1.500	2.126	0.110	D3143900M-150F
	1.555	39.50	4.665	5.882	8.598	1.500	2.126	0.105	D3143950M-150F
	1.562	39.67	4.686	5.882	8.598	1.500	2.126	0.103	D3141562I-150F
	1.575	40.00	4.724	6.000	8.717	1.500	2.126	0.098	D3144000M-150F
	1.594	40.50	4.783	6.000	8.717	1.500	2.126	0.095	D3144050M-150F
	1.614	41.00	4.843	6.118	8.835	1.500	2.126	0.091	D3144100M-150F
	1.625	41.28	4.875	6.118	8.835	1.500	2.126	0.088	D3141625I-150F
	1.634	41.50	4.902	6.118	8.835	1.500	2.126	0.085	D3144150M-150F
	1.654	42.00	4.961	6.236	8.953	1.500	2.126	0.079	D3144200M-150F
	1.673	42.50	5.020	6.236	8.953	1.500	2.126	0.075	D3144250M-150F
	1.687	42.85	5.061	6.236	8.953	1.500	2.126	0.072	D3141687I-150F
	1.693	43.00	5.079	6.354	9.071	1.500	2.323	0.071	D3144300M-150F

IC Inserts

ISO Material	Part No.	Insert Screw	Torx® Driver	Admissible Tightening Torque
P	4T-140408-P	7595-T20-1	8T-20	39.8 in-lbs (4.5 N-m)
S M	4T-140408-M			
H	4T-140408-H			
K	4T-140408-K			
N	4T-140408-N			

Expected Hole Tolerances

Length	in	mm
2xD	-0.08 / +.012	-20 / +.30
3xD	-0.08 / +.012	-20 / +.30
4xD	-0.08 / +.014	-20 / +.35

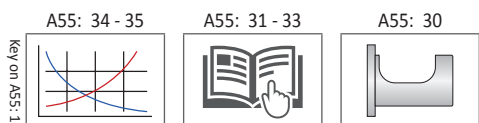

ⓘ = Imperial (in)
Ⓜ = Metric (mm)

IC inserts sold in quantities of 10
Insert screws sold in quantities of 10

4TEX Drill Holders | Imperial Shank

14 Series | Diameter Range: 1.536" - 1.850" (39.00 mm - 47.00 mm)

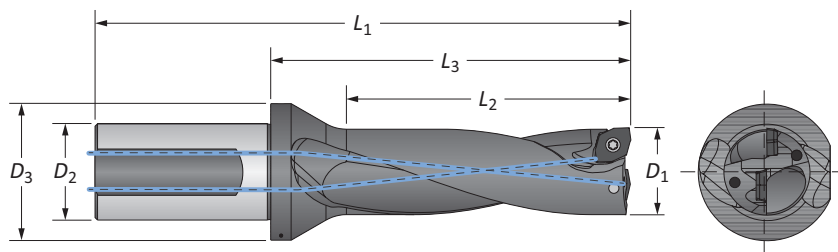

Imperial Shank

Length	D ₁		Body			Shank		Max Offset	Part No.
	in	mm	L ₂	L ₃	L ₁	D ₂	D ₃		
3xD	1.713	43.50	5.138	6.354	9.071	1.500	2.323	0.065	D3144350M-150F
	1.732	44.00	5.197	6.472	9.189	1.500	2.323	0.059	D3144400M-150F
	1.750	44.45	5.250	6.472	9.189	1.500	2.323	0.055	D3141750I-150F
	1.752	44.50	5.256	6.472	9.189	1.500	2.323	0.055	D3144450M-150F
	1.772	45.00	5.315	6.591	9.307	1.500	2.323	0.051	D3144500M-150F
	1.791	45.50	5.374	6.591	9.307	1.500	2.323	0.045	D3144550M-150F
	1.811	46.00	5.433	6.709	9.425	1.500	2.323	0.039	D3144600M-150F
	1.812	46.02	5.436	6.709	9.425	1.500	2.323	0.040	D3141812I-150F
	1.831	46.50	5.492	6.709	9.425	1.500	2.323	0.036	D3144650M-150F
4xD	1.850	47.00	5.551	6.827	9.543	1.500	2.323	0.031	D3144700M-150F
	1.535	39.00	6.142	7.417	10.134	1.500	2.126	0.110	D4143900M-150F
	1.555	39.50	6.220	7.417	10.134	1.500	2.126	0.105	D4143950M-150F
	1.562	39.67	6.248	7.417	10.134	1.500	2.126	0.103	D4141562I-150F
	1.575	40.00	6.299	7.575	10.291	1.500	2.126	0.098	D4144000M-150F
	1.594	40.50	6.378	7.575	10.291	1.500	2.126	0.095	D4144050M-150F
	1.614	41.00	6.457	7.732	10.449	1.500	2.126	0.091	D4144100M-150F
	1.625	41.28	6.500	7.732	10.449	1.500	2.126	0.088	D4141625I-150F
	1.634	41.50	6.535	7.732	10.449	1.500	2.126	0.085	D4144150M-150F
	1.654	42.00	6.614	7.890	10.606	1.500	2.126	0.079	D4144200M-150F
	1.673	42.50	6.693	7.890	10.606	1.500	2.126	0.075	D4144250M-150F
	1.687	42.85	6.748	7.890	10.606	1.500	2.126	0.072	D4141687I-150F
	1.693	43.00	6.772	8.047	10.764	1.500	2.323	0.071	D4144300M-150F
	1.713	43.50	6.850	8.047	10.764	1.500	2.323	0.065	D4144350M-150F
	1.732	44.00	6.929	8.205	10.921	1.500	2.323	0.059	D4144400M-150F
	1.750	44.45	7.000	8.205	10.921	1.500	2.323	0.055	D4141750I-150F
	1.752	44.50	7.008	8.205	10.921	1.500	2.323	0.055	D4144450M-150F
	1.772	45.00	7.087	8.362	11.079	1.500	2.323	0.051	D4144500M-150F
	1.791	45.50	7.165	8.362	11.079	1.500	2.323	0.045	D4144550M-150F
	1.811	46.00	7.244	8.520	11.236	1.500	2.323	0.039	D4144600M-150F
1.812	46.02	7.248	8.520	11.236	1.500	2.323	0.040	D4141812I-150F	
1.831	46.50	7.323	8.520	11.236	1.500	2.323	0.036	D4144650M-150F	
1.850	47.00	7.402	8.677	11.394	1.500	2.323	0.031	D4144700M-150F	

IC Inserts

ISO Material	Part No.	Insert Screw	Torx® Driver	Admissible Tightening Torque
P	4T-140408-P	7595-T20-1	8T-20	39.8 in-lbs (4.5 N-m)
S M	4T-140408-M			
H	4T-140408-H			
K	4T-140408-K			
N	4T-140408-N			

Expected Hole Tolerances

Length	in	mm
2xD	-.008 / +.012	-.20 / +.30
3xD	-.008 / +.012	-.20 / +.30
4xD	-.008 / +.014	-.20 / +.35

A55: 34 - 35

A55: 31 - 33

A55: 30

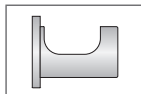
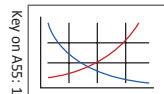

ⓘ = Imperial (in)
Ⓜ = Metric (mm)

IC inserts sold in quantities of 10
Insert screws sold in quantities of 10

4TEX Drill Holders | Metric Shank

14 Series | Diameter Range: 1.536" - 1.850" (39.00 mm - 47.00 mm)

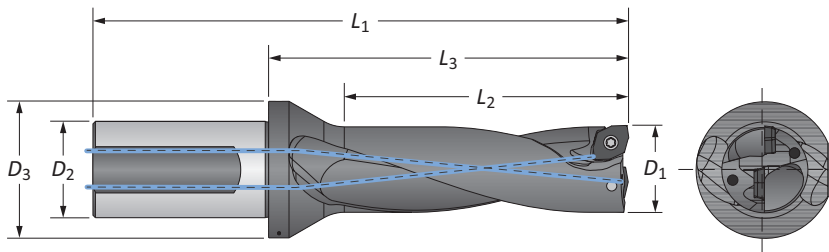

Metric Shank

Length	D ₁		Body			Shank		Max Offset	Part No.
	in	mm	L ₂	L ₃	L ₁	D ₂	D ₃		
2xD	1.535	39.00	78.00	110.40	179.40	40.00	54.00	2.80	D2143900M-40FM
	1.555	39.50	79.00	110.40	179.40	40.00	54.00	2.66	D2143950M-40FM
	1.562	39.67	79.40	110.40	179.40	40.00	54.00	2.61	D2141562I-40FM
	1.575	40.00	80.00	112.40	181.40	40.00	54.00	2.50	D2144000M-40FM
	1.594	40.50	81.00	112.40	181.40	40.00	54.00	2.41	D2144050M-40FM
	1.614	41.00	82.00	114.40	183.40	40.00	54.00	2.30	D2144100M-40FM
	1.625	41.28	82.55	114.40	183.40	40.00	54.00	2.23	D2141625I-40FM
	1.634	41.50	83.00	114.40	183.40	40.00	54.00	2.16	D2144150M-40FM
	1.654	42.00	84.00	116.40	185.40	40.00	54.00	2.00	D2144200M-40FM
	1.673	42.50	85.00	116.40	185.40	40.00	54.00	1.90	D2144250M-40FM
	1.687	42.85	85.70	116.40	185.40	40.00	54.00	1.82	D2141687I-40FM
	1.693	43.00	86.00	118.40	187.40	40.00	59.00	1.80	D2144300M-40FM
	1.713	43.50	87.00	118.40	187.40	40.00	59.00	1.65	D2144350M-40FM
	1.732	44.00	88.00	120.40	189.40	40.00	59.00	1.50	D2144400M-40FM
	1.750	44.45	88.90	120.40	189.40	40.00	59.00	1.41	D2141750I-40FM
	1.752	44.50	89.00	120.40	189.40	40.00	59.00	1.40	D2144450M-40FM
	1.772	45.00	90.00	122.40	191.40	40.00	59.00	1.30	D2144500M-40FM
	1.791	45.50	91.00	122.40	191.40	40.00	59.00	1.15	D2144550M-40FM
1.812	46.02	92.10	124.40	193.40	40.00	59.00	1.02	D2141812I-40FM	
1.811	46.00	92.00	124.40	193.40	40.00	59.00	1.00	D2144600M-40FM	
1.831	46.50	93.00	124.40	193.40	40.00	59.00	0.90	D2144650M-40FM	
1.850	47.00	94.00	126.40	195.40	40.00	59.00	0.80	D2144700M-40FM	
3xD	1.535	39.00	117.00	149.40	218.40	40.00	54.00	2.80	D3143900M-40FM
	1.555	39.50	118.50	149.40	218.40	40.00	54.00	2.66	D3143950M-40FM
	1.562	39.67	119.02	149.40	218.40	40.00	54.00	2.61	D3141562I-40FM
	1.575	40.00	120.00	152.40	221.40	40.00	54.00	2.50	D3144000M-40FM
	1.594	40.50	121.50	152.40	221.40	40.00	54.00	2.41	D3144050M-40FM
	1.614	41.00	123.00	155.40	224.40	40.00	54.00	2.30	D3144100M-40FM
	1.625	41.28	123.83	155.40	224.40	40.00	54.00	2.23	D3141625I-40FM
	1.634	41.50	124.50	155.40	224.40	40.00	54.00	2.16	D3144150M-40FM
	1.654	42.00	126.00	158.40	227.40	40.00	54.00	2.00	D3144200M-40FM
	1.673	42.50	127.50	158.40	227.40	40.00	54.00	1.90	D3144250M-40FM
	1.687	42.85	128.55	158.40	227.40	40.00	54.00	1.82	D3141687I-40FM
	1.693	43.00	129.00	161.40	230.40	40.00	59.00	1.80	D3144300M-40FM

IC Inserts

ISO Material	Part No.	Insert Screw	Torx® Driver	Admissible Tightening Torque
P	4T-140408-P	7595-T20-1	8T-20	39.8 in-lbs (4.5 N-m)
S	4T-140408-M			
H	4T-140408-H			
K	4T-140408-K			
N	4T-140408-N			

Expected Hole Tolerances

Length	in	mm
2xD	-0.008 / +.012	-0.20 / +.30
3xD	-0.008 / +.012	-0.20 / +.30
4xD	-0.008 / +.014	-0.20 / +.35

A55: 34 - 35 A55: 31 - 33 A55: 30

Key on A55: 1

i = Imperial (in)
m = Metric (mm)

IC inserts sold in quantities of 10
Insert screws sold in quantities of 10

4TEX Drill Holders | Metric Shank

14 Series | Diameter Range: 1.536" - 1.850" (39.00 mm - 47.00 mm)

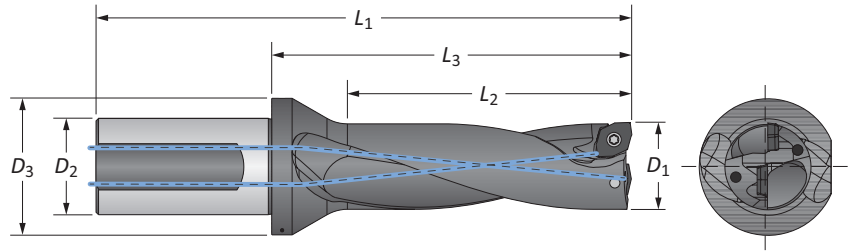

Metric Shank

Length	D ₁		Body			Shank		Max Offset	Part No.
	in	mm	L ₂	L ₃	L ₁	D ₂	D ₃		
3xD	1.713	43.50	130.50	161.40	230.40	40.00	59.00	1.65	D3144350M-40FM
	1.732	44.00	132.00	164.40	233.40	40.00	59.00	1.50	D3144400M-40FM
	1.750	44.45	133.35	164.40	233.40	40.00	59.00	1.41	D3141750I-40FM
	1.752	44.50	133.50	164.40	233.40	40.00	59.00	1.40	D3144450M-40FM
	1.772	45.00	135.00	167.40	236.40	40.00	59.00	1.30	D3144500M-40FM
	1.791	45.50	136.50	167.40	236.40	40.00	59.00	1.15	D3144550M-40FM
	1.811	46.00	138.00	170.40	239.40	40.00	59.00	1.00	D3144600M-40FM
	1.812	46.02	138.07	170.40	239.40	40.00	59.00	1.02	D3141812I-40FM
	1.831	46.50	139.50	170.40	239.40	40.00	59.00	0.90	D3144650M-40FM
1.850	47.00	141.00	173.40	242.40	40.00	59.00	0.80	D3144700M-40FM	
4xD	1.535	39.00	156.00	188.40	257.40	40.00	54.00	2.80	D4143900M-40FM
	1.555	39.50	158.00	188.40	257.40	40.00	54.00	2.66	D4143950M-40FM
	1.562	39.67	158.70	188.40	257.40	40.00	54.00	2.61	D4141562I-40FM
	1.575	40.00	160.00	192.40	261.40	40.00	54.00	2.50	D4144000M-40FM
	1.594	40.50	162.00	192.40	261.40	40.00	54.00	2.41	D4144050M-40FM
	1.614	41.00	164.00	196.40	265.40	40.00	54.00	2.30	D4144100M-40FM
	1.625	41.28	165.10	196.40	265.40	40.00	54.00	2.23	D4141625I-40FM
	1.634	41.50	166.00	196.40	265.40	40.00	54.00	2.16	D4144150M-40FM
	1.654	42.00	168.00	200.40	269.40	40.00	54.00	2.00	D4144200M-40FM
	1.673	42.50	170.00	200.40	269.40	40.00	54.00	1.90	D4144250M-40FM
	1.687	42.85	171.40	200.40	269.40	40.00	54.00	1.82	D4141687I-40FM
	1.693	43.00	172.00	204.40	273.40	40.00	59.00	1.80	D4144300M-40FM
	1.713	43.50	174.00	204.40	273.40	40.00	59.00	1.65	D4144350M-40FM
	1.732	44.00	176.00	208.40	277.40	40.00	59.00	1.50	D4144400M-40FM
	1.750	44.45	177.80	208.40	277.40	40.00	59.00	1.41	D4141750I-40FM
	1.752	44.50	178.00	208.40	277.40	40.00	59.00	1.40	D4144450M-40FM
	1.772	45.00	180.00	212.40	281.40	40.00	59.00	1.30	D4144500M-40FM
	1.791	45.50	182.00	212.40	281.40	40.00	59.00	1.15	D4144550M-40FM
	1.811	46.00	184.00	216.40	285.40	40.00	59.00	1.00	D4144600M-40FM
	1.812	46.02	184.10	216.40	285.40	40.00	59.00	1.02	D4141812I-40FM
1.831	46.50	186.00	216.40	285.40	40.00	59.00	0.90	D4144650M-40FM	
1.850	47.00	188.00	220.40	289.40	40.00	59.00	0.80	D4144700M-40FM	

IC Inserts

ISO Material	Part No.	Insert Screw	Torx® Driver	Admissible Tightening Torque
P	4T-140408-P	7595-T20-1	8T-20	39.8 in-lbs (4.5 N-m)
S M	4T-140408-M			
H	4T-140408-H			
K	4T-140408-K			
N	4T-140408-N			

Expected Hole Tolerances

Length	in	mm
2xD	-.008 / +.012	-.20 / +.30
3xD	-.008 / +.012	-.20 / +.30
4xD	-.008 / +.014	-.20 / +.35

Key on ASS-1

A55: 34 - 35

A55: 31 - 33

A55: 30

ⓘ = Imperial (in)
 ⓘ = Metric (mm)

IC inserts sold in quantities of 10
 Insert screws sold in quantities of 10

A
DRILLING
B
BORING
C
REAMING
D
BURNISHING
E
THREADING
X
SPECIALS

Eccentric Sleeves

For Cutting Diameter / Center Height Adjustment

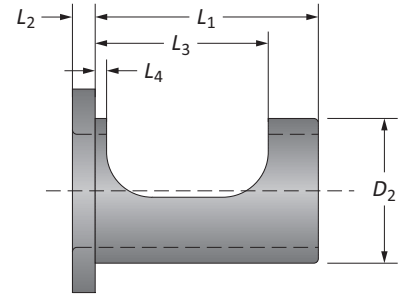
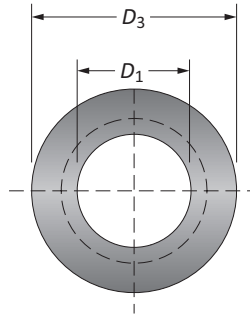

Sleeve Dimensions							Adjustment Range		
D_1	D_2	D_3	L_2	L_3	L_4	L_1	Part No.	Diameter*	Center Height
0.750	1.000	1.614	0.157	1.593	0.118	1.837	SLEEVE-075F	-0.008 to +0.016	-0.006 to +0.008
1.000	1.250	1.929	0.236	1.593	0.098	1.995	SLEEVE-100F	-0.008 to +0.016	-0.006 to +0.008
1.250	1.500	2.283	0.236	1.693	0.098	2.087	SLEEVE-125F	-0.008 to +0.016	-0.006 to +0.008
1.500	2.000	2.913	0.236	1.929	0.118	2.481	SLEEVE-150F	-0.008 to +0.024	-0.008 to +0.012
<hr/>									
25.00	32.00	49.00	6.00	39.00	2.50	54.00	SLEEVE-25FM	-0.20 to +0.40	-0.15 to +0.20
32.00	40.00	58.00	6.00	43.00	2.50	59.00	SLEEVE-32FM	-0.20 to +0.40	-0.15 to +0.20
40.00	50.00	74.00	6.00	49.00	3.00	69.00	SLEEVE-40FM	-0.20 to +0.40	-0.20 to +0.30

*Diameter adjustment range refers to the cutting diameter.

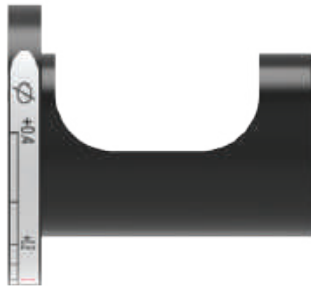

Milling Applications
Peripheral Adjustment Position

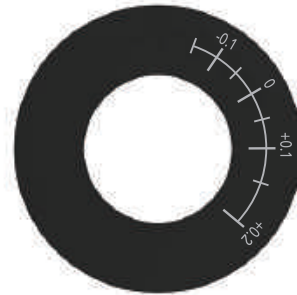

Lathe Applications
Front Adjustment Position

i = Imperial (in)
m = Metric (mm)



Diameter Adjustment

Milling and Lathe Applications

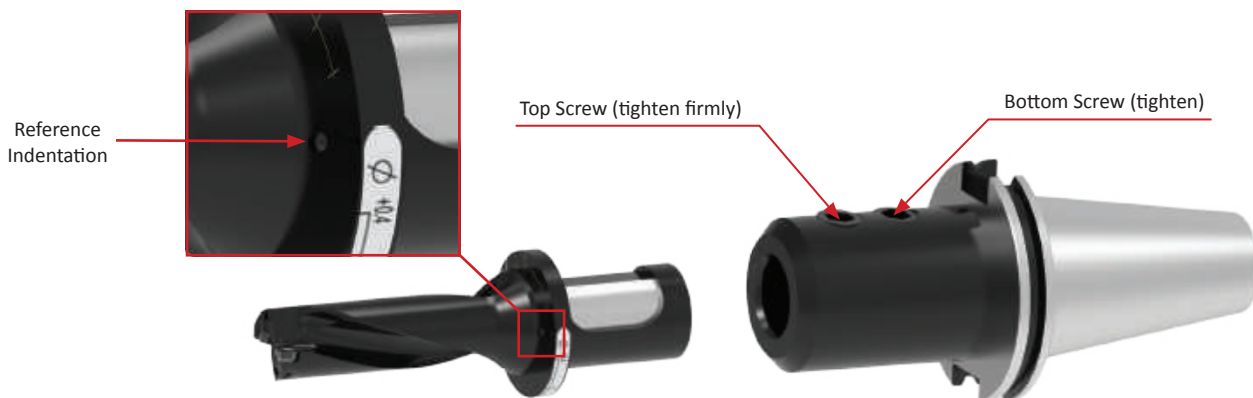

For Milling Applications

1. Assemble the 4TEX drill, eccentric sleeve, and tool holder. Do not tighten the tool holder set screws.
2. Using the peripheral marks for milling machines, align the reference indentation on the holder with the 0 (zero) mark on the eccentric sleeve to have no offset.
3. Rotate the sleeve in the (+) or (-) direction to increase or decrease the nominal diameter.
4. Once the drill has arrived at the desired diameter, firmly tighten the top set screw first and then tighten the bottom set screw.

NOTICE: Eccentric sleeves are to be used with side-locking tool holders only. Damage may result with other styles of tool holders.

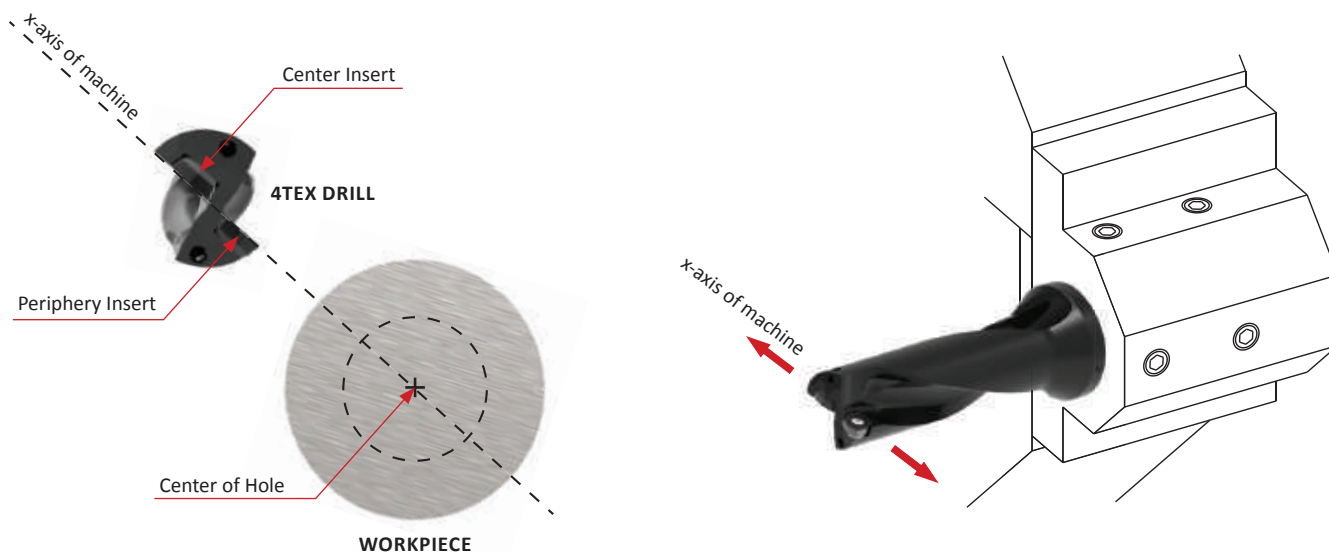

For Lathe Applications

1. Assemble the 4TEX drill into the lathe turret with the top face of the inserts parallel to the x-axis of the machine. This will allow for the diameter offsets to be made using the lathe's x-axis.
2. To increase the nominal diameter, offset the x-axis so the periphery insert moves away from the center of the hole.
3. To decrease the nominal diameter, offset the x-axis so the periphery insert moves toward the center of the hole.

NOTE: Eccentric sleeve is not required when adjusting the diameter of the hole on a lathe.

Center Height Alignment

Proper Center Line Position

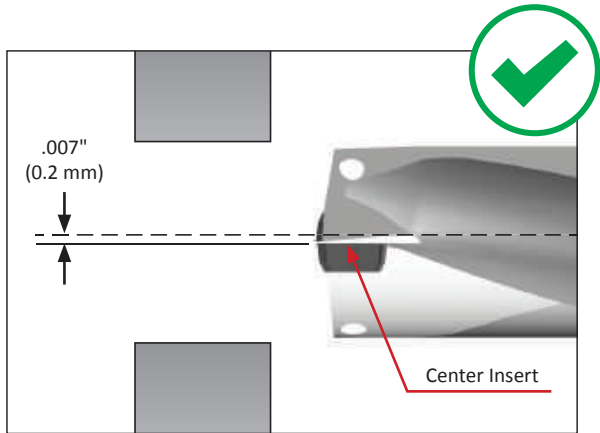
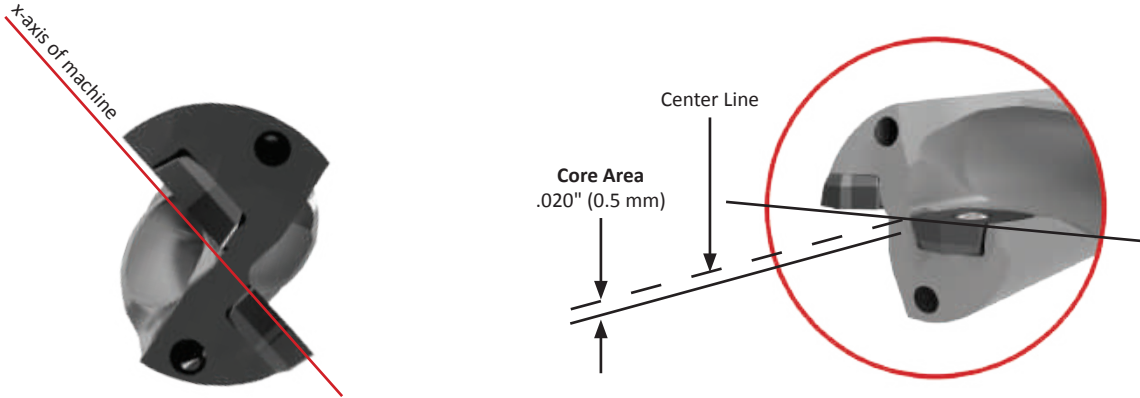

Proper Center Height Alignment

- The correct center height alignment will position the center insert .007" (0.2 mm) below the center line.

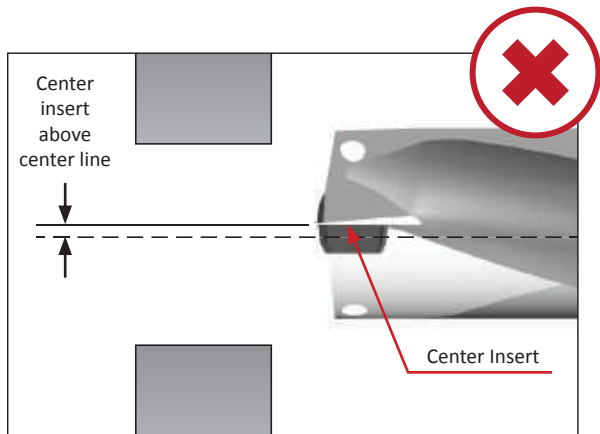
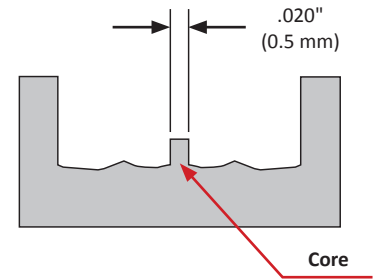

Center Insert Above the Center Line

- This will cause fracturing of the center insert
- Requires center height adjustment

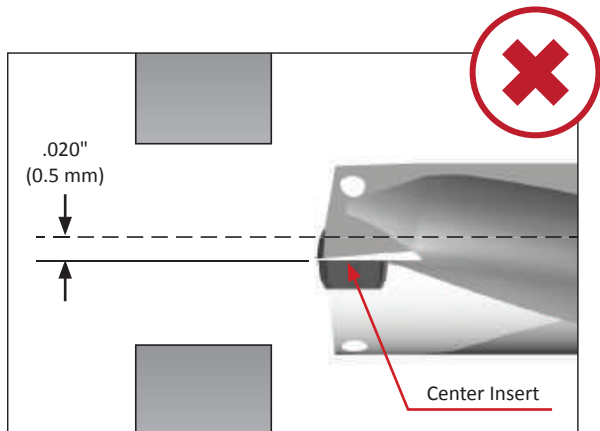
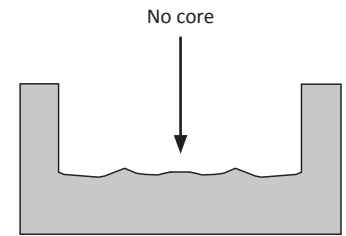

Center Insert Too Far Below Center Line

- This will cause the drill to interfere with the drilled hole
- This will impede chip evacuation on the periphery insert
- Requires center height adjustment

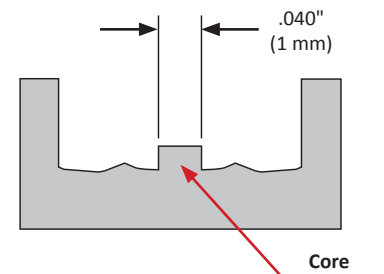



Center Height Alignment

How to Correct Issues

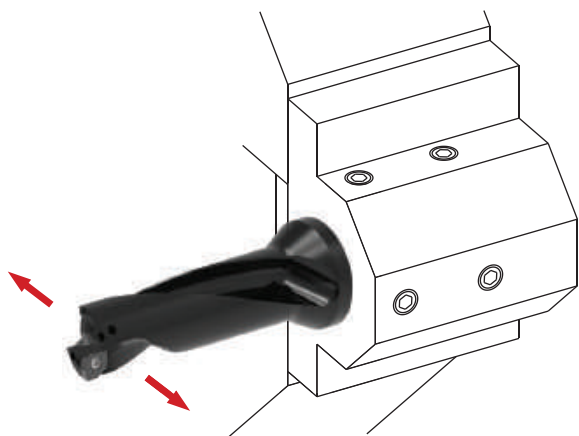

Method 1: Adjustment with X-Axis

1. Rotate the drill body so the position of the center line of the inserts is perpendicular to the lathe's x-axis.
2. Use the x-axis to offset the position of the center line in a (+) or (-) direction to increase or decrease the center core diameter at the bottom of the hole.

NOTE: This method does not allow diameter adjustments using the x-axis.

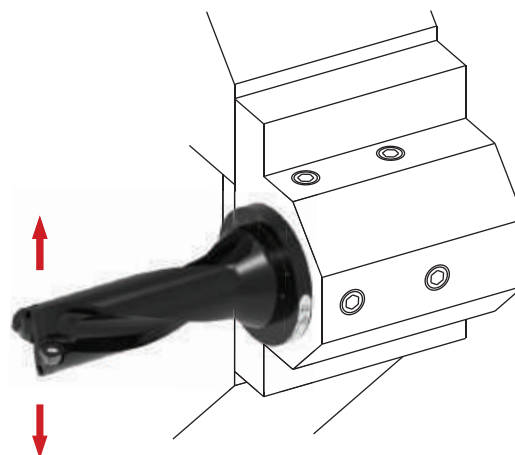

Method 2: Adjustment with Eccentric Sleeve

1. Assemble the drill to the turret using the eccentric sleeve, positioning the center line of the inserts parallel to the x-axis.
2. Align the reference indentation on the drill to the "0" setting on the flange face.
3. Rotate the sleeve (+) or (-) to increase or decrease the center height of the inserts in order to increase or decrease the core diameter at the bottom of the hole.

NOTE: This method still allows diameter adjustments using the x-axis.

NOTE (applies to both methods): Adjusting the center line of the inserts may affect the hole diameter produced. Method two is preferred to make center height adjustments and compensate for hole diameter with the x-axis.

A

DRILLING

B

BORING

C

REAMING

D

BURNISHING

E

THREADING

X

SPECIALS



Recommended Drilling Data | Imperial (inch)

ISO	Material	Hardness (BHN)	Speed (SFM)				Feed Rate (IPR) by Diameter - 2xD, 3xD**				
			P	K	H	M	N	03, 04 Series	05 Series	06, 07 Series	09, 11, 14 Series
			AM480	AM485	TiCN			Ø 0.472" - 0.609"	Ø 0.610" - 0.728"	Ø 0.729" - 1.043"	Ø 1.044" - 1.850"
P	Free-Machining Steel 1118, 1215, 12L14, etc.	100-150	400 - 1200	400 - 1200	-	0.0025 - 0.004	0.0025 - 0.005	0.003 - 0.0055	0.003 - 0.0055		
		150-200	400 - 1000	400 - 1000	-	0.0025 - 0.004	0.0025 - 0.005	0.003 - 0.0055	0.003 - 0.0055		
		200-250	400 - 800	400 - 800	-	0.0025 - 0.004	0.0025 - 0.005	0.003 - 0.0055	0.003 - 0.0055		
	Low-Carbon Steel 1010, 1020, 1025, 1522, 1144, etc.	85-125	400 - 1000	400 - 1000	-	0.0025 - 0.004	0.0025 - 0.005	0.003 - 0.0055	0.003 - 0.0055		
		125-175	400 - 1000	400 - 1000	-	0.0025 - 0.004	0.0025 - 0.005	0.003 - 0.0055	0.003 - 0.0055		
		175-225	400 - 800	400 - 800	-	0.0025 - 0.004	0.0025 - 0.005	0.003 - 0.0055	0.003 - 0.0055		
	Medium-Carbon Steel 1030, 1040, 1050, 1527, 1140, 1151, etc.	225-275	400 - 800	400 - 800	-	0.0025 - 0.004	0.0025 - 0.005	0.003 - 0.0055	0.003 - 0.0055		
		125-175	330 - 800	330 - 800	-	0.0015 - 0.0055	0.0025 - 0.0065	0.003 - 0.008	0.003 - 0.008		
		175-225	330 - 800	330 - 800	-	0.0015 - 0.0055	0.0025 - 0.0065	0.003 - 0.008	0.003 - 0.008		
	Alloy Steel 4140, 5140, 8640, etc.	225-275	330 - 800	330 - 800	-	0.0015 - 0.0055	0.0025 - 0.0065	0.003 - 0.008	0.003 - 0.008		
		275-325	330 - 800	330 - 800	-	0.0015 - 0.0055	0.0025 - 0.0065	0.003 - 0.008	0.003 - 0.008		
		325-375	330 - 600	330 - 600	-	0.0015 - 0.0055	0.0025 - 0.0065	0.003 - 0.008	0.003 - 0.008		
	High-Strength Alloy 4340, 4330V, 300M, etc.	125-175	330 - 800	-	-	0.0015 - 0.0055	0.0025 - 0.0065	0.003 - 0.008	0.003 - 0.008		
		175-225	330 - 800	-	-	0.0015 - 0.0055	0.0025 - 0.0065	0.003 - 0.008	0.003 - 0.008		
		225-275	330 - 800	-	-	0.0015 - 0.0055	0.0025 - 0.0065	0.003 - 0.008	0.003 - 0.008		
	Structural Steel A36, A285, A516, etc.	275-325	330 - 800	-	-	0.0015 - 0.0055	0.0025 - 0.0065	0.003 - 0.008	0.003 - 0.008		
		325-375	330 - 800	-	-	0.0015 - 0.0055	0.0025 - 0.0065	0.003 - 0.008	0.003 - 0.008		
		375-425	330 - 800	-	-	0.0015 - 0.0055	0.0025 - 0.0065	0.003 - 0.008	0.003 - 0.008		
	Tool Steel H-13, H-21, A-4, O-2, S-3, etc.	100-150	330 - 600	330 - 600	-	0.0015 - 0.0055	0.0025 - 0.0065	0.003 - 0.008	0.003 - 0.008		
		150-200	330 - 600	330 - 600	-	0.0015 - 0.0055	0.0025 - 0.0065	0.003 - 0.008	0.003 - 0.008		
S	High-Temp Alloy* Hastelloy B, Inconel 600, etc.	250-350	330 - 600	-	-	0.0015 - 0.0055	0.0025 - 0.0065	0.003 - 0.008	0.003 - 0.008		
		350-400	330 - 600	-	-	0.0015 - 0.0055	0.0025 - 0.0065	0.003 - 0.008	0.003 - 0.008		
	Titanium Alloy*	150-200	270 - 600	270 - 600	-	0.0015 - 0.003	0.0025 - 0.005	0.003 - 0.006	0.003 - 0.006		
		200-250	270 - 600	-	-	0.0015 - 0.003	0.0025 - 0.005	0.003 - 0.006	0.003 - 0.006		
	Aerospace Alloy* S82	140 - 220	100 - 250	100 - 250	-	0.002 - 0.003	0.002 - 0.003	0.0025 - 0.004	0.0025 - 0.004		
		220 - 310	100 - 200	100 - 200	-	0.002 - 0.003	0.002 - 0.003	0.0025 - 0.004	0.0025 - 0.004		
M	Stainless Steel 400 Series 416, 420, etc.	140 - 220	140 - 500	140 - 500	-	0.002 - 0.003	0.002 - 0.003	0.0025 - 0.004	0.0025 - 0.004		
		220 - 310	140 - 300	140 - 300	-	0.002 - 0.003	0.002 - 0.003	0.0025 - 0.004	0.0025 - 0.004		
	Stainless Steel 300 Series 304, 316, 17-4PH, etc.	185 - 275	100 - 250	100 - 250	-	0.002 - 0.003	0.002 - 0.003	0.0025 - 0.004	0.0025 - 0.004		
		275 - 350	100 - 200	100 - 200	-	0.002 - 0.003	0.002 - 0.003	0.0025 - 0.004	0.0025 - 0.004		
	Super Duplex Stainless Steel	185 - 275	240 - 600	240 - 700	-	0.0015 - 0.004	0.0025 - 0.005	0.0025 - 0.0055	0.0025 - 0.0055		
275 - 350		240 - 470	240 - 500	-	0.0015 - 0.004	0.0025 - 0.005	0.0025 - 0.0055	0.0025 - 0.0055			
H	Wear Plate Hardox®, AR400, T-1, etc.	135 - 185	240 - 600	240 - 700	-	0.0015 - 0.004	0.0025 - 0.005	0.0025 - 0.0055	0.0025 - 0.0055		
		185 - 275	240 - 470	240 - 500	-	0.0015 - 0.004	0.0025 - 0.005	0.0025 - 0.0055	0.0025 - 0.0055		
		135 - 185	240 - 600	240 - 700	-	0.0015 - 0.004	0.0025 - 0.005	0.0025 - 0.0055	0.0025 - 0.0055		
	185 - 275	240 - 470	240 - 500	-	0.0015 - 0.004	0.0025 - 0.005	0.0025 - 0.0055	0.0025 - 0.0055			
Hardened Steel	400	100 - 200	-	-	0.0015 - 0.003	0.0025 - 0.005	0.003 - 0.006	0.003 - 0.006			
	500	100 - 200	-	-	0.0015 - 0.003	0.0025 - 0.005	0.003 - 0.006	0.003 - 0.006			
K	Nodular, Grey, Ductile Cast Iron	600	100 - 200	-	-	0.0015 - 0.003	0.0025 - 0.005	0.003 - 0.006	0.003 - 0.006		
		300 - 400	100 - 300	-	-	0.0015 - 0.003	0.0025 - 0.005	0.003 - 0.006	0.003 - 0.006		
		400 - 500	100 - 200	-	-	0.0015 - 0.003	0.0025 - 0.005	0.003 - 0.006	0.003 - 0.006		
		120 - 150	300 - 800	-	-	0.003 - 0.0055	0.003 - 0.007	0.003 - 0.008	0.003 - 0.008		
		150 - 200	300 - 800	-	-	0.003 - 0.0055	0.003 - 0.007	0.003 - 0.008	0.003 - 0.008		
N	Cast Aluminum	200 - 220	300 - 500	-	-	0.003 - 0.0055	0.003 - 0.007	0.003 - 0.008	0.003 - 0.008		
		220 - 260	270 - 400	-	-	0.003 - 0.0055	0.003 - 0.007	0.003 - 0.008	0.003 - 0.008		
	Wrought Aluminum	260 - 320	270 - 400	-	-	0.003 - 0.0055	0.003 - 0.007	0.003 - 0.008	0.003 - 0.008		
		30	-	-	800 - 2000	0.0025 - 0.005	0.003 - 0.0055	0.003 - 0.0065	0.003 - 0.008		
	Aluminum Bronze	180	-	-	800 - 2000	0.0025 - 1.005	0.003 - 0.0055	0.003 - 0.0065	0.003 - 0.008		
		30	-	-	800 - 2000	0.0025 - 0.005	0.003 - 0.0055	0.003 - 0.0065	0.003 - 0.008		
	Brass	180	-	-	800 - 2000	0.0025 - 0.005	0.003 - 0.0055	0.003 - 0.0065	0.003 - 0.008		
		100 - 200	500 - 1000	-	500 - 1000	0.0025 - 0.005	0.003 - 0.0055	0.003 - 0.0065	0.003 - 0.008		
Copper	200 - 250	500 - 1000	-	500 - 1000	0.0025 - 0.005	0.003 - 0.0055	0.003 - 0.0065	0.003 - 0.008			
	100	500 - 1000	-	500 - 1000	0.0025 - 0.005	0.003 - 0.0055	0.003 - 0.0065	0.003 - 0.008			

*For high-temp materials, 1000 PSI is recommended as well as a quality synthetic coolant at approximately 10% emulsion.

**For 4xD tools, begin at low end of feed recommendation.

IMPORTANT: The speeds and feeds listed above are a general starting point for all applications. Factory technical assistance is also available through our Application Engineering Team.
ext: 7611 | email: appeng@alliedmachine.com

Recommended Drilling Data | Metric (mm)

ISO	Material	Hardness (BHN)	Speed (M/min)				Feed Rate (mm/rev) by Diameter - 2xD, 3xD**			
			P AM480	K AM485	H TiCN	M TiCN	03, 04 Series Ø 12.00mm - 15.49mm	05 Series Ø 15.50mm - 18.49mm	06, 07 Series Ø 18.50mm - 26.49mm	09, 11, 14 Series Ø 26.50mm - 47.00mm
P	Free-Machining Steel 1118, 1215, 12L14, etc.	100 - 150	125 - 365	125 - 365	-	0.07 - 0.1	0.07 - 0.12	0.08 - 0.14	0.08 - 0.14	
		150 - 200	125 - 305	125 - 305	-	0.07 - 0.1	0.07 - 0.12	0.08 - 0.14	0.08 - 0.14	
		200 - 250	125 - 245	125 - 245	-	0.07 - 0.1	0.07 - 0.12	0.08 - 0.14	0.08 - 0.14	
	Low-Carbon Steel 1010, 1020, 1025, 1522, 1144, etc.	85 - 125	125 - 305	125 - 305	-	0.07 - 0.1	0.07 - 0.12	0.08 - 0.14	0.08 - 0.14	
		125 - 175	125 - 305	125 - 305	-	0.07 - 0.1	0.07 - 0.12	0.08 - 0.14	0.08 - 0.14	
		175 - 225	125 - 245	125 - 245	-	0.07 - 0.1	0.07 - 0.12	0.08 - 0.14	0.08 - 0.14	
		225 - 275	125 - 245	125 - 245	-	0.07 - 0.1	0.07 - 0.12	0.08 - 0.14	0.08 - 0.14	
	Medium-Carbon Steel 1030, 1040, 1050, 1527, 1140, 1151, etc.	125 - 175	100 - 245	100 - 245	-	0.05 - 0.14	0.07 - 0.17	0.08 - 0.21	0.08 - 0.21	
		175 - 225	100 - 245	100 - 245	-	0.05 - 0.14	0.07 - 0.17	0.08 - 0.21	0.08 - 0.21	
		225 - 275	100 - 245	100 - 245	-	0.05 - 0.14	0.07 - 0.17	0.08 - 0.21	0.08 - 0.21	
		275 - 325	100 - 245	100 - 185	-	0.05 - 0.14	0.07 - 0.17	0.08 - 0.21	0.08 - 0.21	
	Alloy Steel 4140, 5140, 8640, etc.	125 - 175	100 - 245	-	-	0.05 - 0.14	0.07 - 0.17	0.08 - 0.21	0.08 - 0.21	
		175 - 225	100 - 245	-	-	0.05 - 0.14	0.07 - 0.17	0.08 - 0.21	0.08 - 0.21	
		225 - 275	100 - 245	-	-	0.05 - 0.14	0.07 - 0.17	0.08 - 0.21	0.08 - 0.21	
		275 - 325	100 - 245	-	-	0.05 - 0.14	0.07 - 0.17	0.08 - 0.21	0.08 - 0.21	
		325 - 375	100 - 245	-	-	0.05 - 0.14	0.07 - 0.17	0.08 - 0.21	0.08 - 0.21	
	High-Strength Alloy 4340, 4330V, 300M, etc.	225 - 300	100 - 165	-	-	0.05 - 0.14	0.07 - 0.17	0.08 - 0.21	0.08 - 0.21	
		300 - 350	100 - 185	-	-	0.05 - 0.14	0.07 - 0.17	0.08 - 0.21	0.08 - 0.21	
		350 - 400	100 - 185	-	-	0.05 - 0.14	0.07 - 0.17	0.08 - 0.21	0.08 - 0.21	
	Structural Steel A36, A285, A516, etc.	100 - 150	100 - 185	100 - 185	-	0.05 - 0.13	0.07 - 0.13	0.08 - 0.13	0.08 - 0.13	
		150 - 250	100 - 185	100 - 185	-	0.05 - 0.13	0.07 - 0.13	0.08 - 0.13	0.08 - 0.13	
		250 - 350	100 - 185	-	-	0.05 - 0.13	0.07 - 0.13	0.08 - 0.13	0.08 - 0.13	
	Tool Steel H-13, H-21, A-4, O-2, S-3, etc.	150 - 200	85 - 185	85 - 185	-	0.05 - 0.08	0.07 - 0.12	0.08 - 0.15	0.08 - 0.15	
		200 - 250	85 - 185	-	-	0.05 - 0.08	0.07 - 0.12	0.08 - 0.15	0.08 - 0.15	
S	High-Temp Alloy* Hastelloy B, Inconel 600, etc.	140 - 220	30 - 80	30 - 80	-	0.06 - 0.08	0.06 - 0.08	0.07 - 0.1	0.07 - 0.1	
		220 - 310	30 - 60	30 - 60	-	0.06 - 0.08	0.06 - 0.08	0.07 - 0.1	0.07 - 0.1	
	Titanium Alloy*	140 - 220	40 - 155	40 - 155	-	0.06 - 0.08	0.06 - 0.08	0.07 - 0.1	0.07 - 0.1	
		220 - 310	40 - 90	40 - 90	-	0.06 - 0.08	0.06 - 0.08	0.07 - 0.1	0.07 - 0.1	
Aerospace Alloy* S82	185 - 275	30 - 80	30 - 80	-	0.06 - 0.08	0.06 - 0.08	0.07 - 0.1	0.07 - 0.1		
	275 - 350	30 - 60	31 - 60	-	0.06 - 0.08	0.06 - 0.08	0.07 - 0.1	0.07 - 0.1		
M	Stainless Steel 400 Series 416, 420, etc.	185 - 275	75 - 185	75 - 215	-	0.05 - 0.1	0.07 - 0.12	0.07 - 0.14	0.07 - 0.14	
		275 - 350	75 - 145	75 - 155	-	0.05 - 0.1	0.07 - 0.12	0.07 - 0.14	0.07 - 0.14	
	Stainless Steel 300 Series 304, 316, 17-4PH, etc.	135 - 185	75 - 185	75 - 215	-	0.05 - 0.1	0.07 - 0.12	0.07 - 0.14	0.07 - 0.14	
		185 - 275	75 - 145	75 - 155	-	0.05 - 0.1	0.07 - 0.12	0.07 - 0.14	0.07 - 0.14	
	Super Duplex Stainless Steel	135 - 185	75 - 185	75 - 215	-	0.05 - 0.1	0.07 - 0.12	0.07 - 0.14	0.07 - 0.14	
185 - 275		75 - 145	75 - 155	-	0.05 - 0.1	0.07 - 0.12	0.07 - 0.14	0.07 - 0.14		
H	Wear Plate Hardox®, AR400, T-1, etc.	400	30 - 60	-	-	0.05 - 0.08	0.07 - 0.12	0.08 - 0.15	0.08 - 0.15	
		500	30 - 60	-	-	0.05 - 0.08	0.07 - 0.12	0.08 - 0.15	0.08 - 0.15	
		600	30 - 60	-	-	0.05 - 0.08	0.07 - 0.12	0.08 - 0.15	0.08 - 0.15	
	Hardened Steel	300 - 400	30 - 90	-	-	0.05 - 0.08	0.07 - 0.12	0.08 - 0.15	0.08 - 0.15	
400 - 500		30 - 60	-	-	0.05 - 0.08	0.07 - 0.12	0.08 - 0.15	0.08 - 0.15		
K	Nodular, Grey, Ductile Cast Iron	120 - 150	90 - 245	-	-	0.08 - 0.14	0.08 - 0.19	0.08 - 0.21	0.08 - 0.21	
		150 - 200	90 - 245	-	-	0.08 - 0.14	0.08 - 0.19	0.08 - 0.21	0.08 - 0.21	
		200 - 220	90 - 155	-	-	0.08 - 0.14	0.08 - 0.19	0.08 - 0.21	0.08 - 0.21	
		220 - 260	80 - 125	-	-	0.08 - 0.14	0.08 - 0.19	0.08 - 0.21	0.08 - 0.21	
		260 - 320	80 - 125	-	-	0.08 - 0.14	0.08 - 0.19	0.08 - 0.21	0.08 - 0.21	
N	Cast Aluminum	30	-	-	245 - 610	0.07 - 0.12	0.08 - 0.14	0.08 - 0.17	0.08 - 0.21	
		180	-	-	245 - 610	0.07 - 0.12	0.08 - 0.14	0.08 - 0.17	0.08 - 0.21	
	Wrought Aluminum	30	-	-	245 - 610	0.07 - 0.12	0.08 - 0.14	0.08 - 0.17	0.08 - 0.21	
		180	-	-	245 - 610	0.07 - 0.12	0.08 - 0.14	0.08 - 0.17	0.08 - 0.21	
	Aluminum Bronze	100 - 200	150 - 305	-	150 - 305	0.07 - 0.12	0.08 - 0.14	0.08 - 0.17	0.08 - 0.21	
		200 - 250	150 - 305	-	150 - 305	0.07 - 0.12	0.08 - 0.14	0.08 - 0.17	0.08 - 0.21	
	Brass	100	150 - 305	-	150 - 305	0.07 - 0.12	0.08 - 0.14	0.08 - 0.17	0.08 - 0.21	
Copper	60	-	-	150 - 305	0.07 - 0.12	0.08 - 0.14	0.08 - 0.17	0.08 - 0.21		

*For high-temp materials, 70 bar is recommended as well as a quality synthetic coolant at approximately 10% emulsion.

**For 4xD tools, begin at low end of feed recommendation.

IMPORTANT: The speeds and feeds listed above are a general starting point for all applications. Factory technical assistance is also available through our Application Engineering Team.
 ext: 7611 | email: appeng@alliedmachine.com

A
DRILLING
B
BORING
C
REAMING
D
BURNISHING
E
THREADING
X
SPECIALS



Insert Geometry Recommendations

ISO	Material	Hardness (BHN)	Geometry				
			P	M	K	N	H
P	Free-Machining Steel 1118, 1215, 12L14, etc.	100 - 150	○	●			
		150 - 200	●	○			
		200 - 250	●	○			
	Low-Carbon Steel 1010, 1020, 1025, 1522, 1144, etc.	85 - 125	○	●			
		125 - 175	○	●			
		175 - 225	○	●			
		225 - 275	●	○			
	Medium-Carbon Steel 1030, 1040, 1050, 1527, 1140, 1151, etc.	125 - 175	○	●			
		175 - 225	○	●			
		225 - 275	●	○			
	Alloy Steel 4140, 5140, 8640, etc.	125 - 175	○	●			
		175 - 225	●	○			
		225 - 275	●				○
		275 - 325	●				○
		325 - 375	○				●
	High-Strength Alloy 4340, 4330V, 300M, etc.	225 - 300	●				
		300 - 350	○				●
		350 - 400	○				●
Structural Steel A36, A285, A516, etc.	100 - 150	○	●				
	150 - 250	○	●				
	250 - 350	●				○	
Tool Steel H-13, H-21, A-4, O-2, S-3, etc.	150 - 200	●	○				
	200 - 250	●				○	
S	High-Temp Alloy* Hastelloy B, Inconel 600, etc.	140 - 220	○	●			
		220 - 310	○	●			
	Titanium Alloy*	140 - 220	○	●			
		220 - 310	○	●			
	Aerospace Alloy* S82	185 - 275	○	●			
275 - 350		○	●				
M	Stainless Steel 400 Series 416, 420, etc.	185 - 275	○	●			
		275 - 350	○	●			
	Stainless Steel 300 Series 304, 316, 17-4PH, etc.	135 - 185	○	●			
		185 - 275	○	●			
	Super Duplex Stainless Steel		○	●			
	135 - 275	○	●				
H	Wear Plate Hardox®, AR400, T-1, etc.	400	○				●
		500	○				●
		600	○				●
	Hardened Steel	300 - 400	○				●
		400 - 500	○				●
K	Nodular, Ductile Cast Iron	120 - 150	●	○			
		150 - 200	●	○			
		200 - 220	●	○			
		220 - 260					○
		260 - 320			●		○
	Grey / White Iron	120 - 150				●	○
		150 - 200				●	○
		200 - 220				●	
		220 - 260				●	
		260 - 320				●	
N	Cast Aluminum	30				●	
		180				●	
	Wrought Aluminum	30				●	
		180				●	
	Aluminum Bronze	100 - 200	○			●	
		200 - 250	○			●	
	Brass	100	○			●	
Copper	60				●		

Troubleshooting

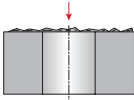
1.  **Starting on Uneven Surfaces**

 - Reduce entry feed by 50% if necessary

2.  **Starting on Angled Surfaces**

 - Reduce entry feed by 20 - 50%
 - Use lower rake geometry if insert chipping occurs

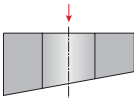
3.  **Angled Bore Exit**

 - Reduce entry feed by 50% on breakout
 - Use tough insert and stable corner radius

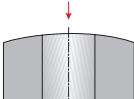
4.  **Starting on Convex Surfaces**

 - Reduce entry feed by 50%
 - Use lower rake geometry if insert chipping occurs

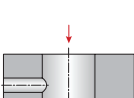
5.  **Drilling Through a Cross Hole**

 - Reduce feed rate 50% if necessary
 - Use good coolant flow and monitor chip packing
 - Use lower rake geometry if insert chipping occurs

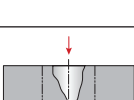
6.  **Drilling on a Groove or Large Centering Box**

 - Reduce entry feed
 - Use lower rake geometry for center insert

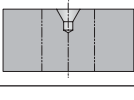
7.  **Chain Drilling**

 - Use good coolant flow
 - Reduce feed rate by 50% for interrupted cut
 - Use lower rake geometry if insert chipping occurs

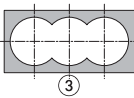
8.  **Starting on an Edge**

 - Reduce entry feed rate by 50%
 - Use lower rake geometry if insert chipping occurs

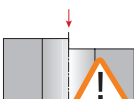
9.  **Starting on a Welded Seam**

 - Reduce entry feed rate by 50%
 - Use lower rake geometry if insert chipping occurs

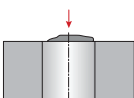
10.  **Drilling Through Stacked Plates**

 - Not recommended

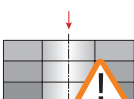
11.  **Opening an Existing Hole**

 - Use flood coolant

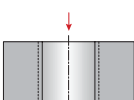
12.  **Adjustable**

 - For mills, use eccentric sleeve with end mill holder
 - For lathes, use x-axis to adjust offset ϕ

NOTE: Refer to maximum offset ϕ in data tables

A

DRILLING

B

BORING

C

REAMING

D

BURNISHING

E

THREADING

X

SPECIALS

Guaranteed Test / Demo Application Form

Distributor PO # _____

The following must be filled out completely before your test will be considered

IMPORTANT: For processing, send Purchase Order to your Allied Field Sales Engineer (FSE). Please clearly mark the paperwork as "Test Order."

Distributor Information

Company Name: _____
 Contact: _____
 Account Number: _____
 Phone: _____
 Email: _____

End User Information

Company Name: _____
 Contact: _____
 Industry: _____
 Phone: _____
 Email: _____

Current Process List all tooling, coatings, substrates, speeds and feeds, tool life, and any problems you are experiencing

Test Objective List what would make this a successful test (i.e. penetration rate, finish, tool life, hole size, etc.)

Application Information

Hole Diameter: _____ in/mm	Tolerance: _____	Material: _____ (4150 / A36 / Cast Iron / etc.)
Preexisting Diameter: _____ in/mm	Depth of Cut: _____ in/mm	Hardness: _____ (BHN / Rc)
Required Finish: _____ RMS	State: _____ (Casting / Hot rolled / Forging)	

Machine Information

Machine Type: _____ (Lathe / Screw machine / Machine center / etc.)	Builder: _____ (Haas, Mori Seiki, etc.)	Model #: _____
Shank Required: _____ (CAT50 / Morse taper, etc.)	Power: _____ HP/KW	
Rigidity: _____	Orientation: _____	Tool Rotating: _____
<input type="checkbox"/> Excellent	<input type="checkbox"/> Vertical	<input type="checkbox"/> Yes
<input type="checkbox"/> Good	<input type="checkbox"/> Horizontal	<input type="checkbox"/> No
<input type="checkbox"/> Poor	Thrust: _____ lbs/N	

Coolant Information

Coolant Delivery: _____ (Through tool / Flood)	Coolant Pressure: _____ PSI / bar
Coolant Type: _____ (Air mist, oil, synthetic, water soluble, etc.)	Coolant Volume: _____ GPM / LPM

Requested Tooling

QTY	Item Number

QTY	Item Number



Allied Machine & Engineering
 120 Deeds Drive
 Dover, OH 44622

Telephone: (330) 343-4283
Toll Free USA & Canada: (800) 321-5537
Fax: (330) 602-3400
Email: info@alliedmachine.com

Warranty Information



Allied Machine & Engineering ("Allied Machine") warrants to original equipment manufacturers, distributors, industrial and commercial users of its products for one year from the original date of sale that each new product manufactured or supplied by Allied Machine shall be free from defects in material and workmanship.

Allied Machine's sole and exclusive obligation under this warranty is limited to, at its option, without additional charge, replacing or repairing this product or issuing a credit. For this warranty to be applied, the product must be returned freight prepaid to the plant designated by an Allied Machine representative and which, upon inspection, is determined by Allied Machine to be defective in material and workmanship.

Complete information as to operating conditions, machine, setup, and the application of cutting fluid should accompany any product returned for inspection. This warranty shall not apply to any Allied Machine products which have been subjected to misuse, abuse, improper operating conditions, improper machine setup or improper application of cutting fluid or which have been repaired or altered if such repair or alteration, in the judgement of Allied Machine, would adversely affect the performance of the product.

THIS WARRANTY IS IN LIEU OF ALL OTHER WARRANTIES, EXPRESS OR IMPLIED, INCLUDING ANY IMPLIED WARRANTY OF MERCHANTABILITY OR FITNESS FOR A PARTICULAR PURPOSE. Allied Machine shall have no liability or responsibility for any claim, whether in contract, tort or otherwise, for any loss or damage arising out of, connected with, or resulting from the manufacture, sale, delivery or use of any product sold hereunder, in excess of the cost of replacement or repair as provided herein.

Allied Machine shall not be liable in contract or in tort (including, without limitation, negligence, strict liability or otherwise) for economic losses of any kind or for any special, incidental, indirect, consequential, punitive or exemplary damages arising in any way out of the performance of, or failure to perform this agreement.

ALL PRICES, DELIVERIES, DESIGNS, AND MATERIALS ARE SUBJECT TO CHANGE WITHOUT NOTICE.



Allied Machine & Engineering
is registered to
ISO 9001:2015 by DQS

United States

Allied Machine & Engineering

120 Deeds Drive
Dover OH 44622
United States

Phone:
+1.330.343.4283

Fax:
+1.330.602.3400

Toll Free USA and Canada:
800.321.5537

Toll Free USA and Canada:
800.223.5140

Allied Machine & Engineering

485 W Third Street
Dover OH 44622
United States

Phone:
+1.330.343.4283

Fax:
+1.330.364.7666
(Engineering Dept.)

Toll Free USA and Canada:
800.321.5537

Europe

Allied Machine & Engineering Co. (Europe) Ltd.

93 Vantage Point
Pensnett Estate
Kingswinford
West Midlands
DY6 7FR England

Phone:
+44 (0) 1384.400900

Wohlhaupter GmbH

Maybachstrasse 4
Postfach 1264
72636 Frickenhausen
Germany

Phone:
+49 (0) 7022.408.0

Fax:
+49 (0) 7022.408.212

Asia

Wohlhaupter India Pvt. Ltd.

B-23, 3rd Floor
B Block Community Centre
Janakpuri, New Delhi - 110058
India

Phone:
+91 (0) 11.41827044

Your local Allied Machine representative:

www.alliedmachine.com

Allied Machine & Engineering is registered to ISO 9001:2015 by DQS

